

TEST REPORT

ACCORDING TO:

FCC 47CFR part 15: 2019, subpart B, Class B

ICES-003: 2017 Issue 6, Class B

AS/NZS CISPR 32: 2015, Class B

EN 55032: 2015, Class B

EN 61000-3-2: 2014

EN 61000-3-3: 2013

EN 55035: 2017

EN 61000-6-3: 2007 + A1 (11) + AC(12)

EN 61000-6-1: 2007

EN IEC 61000-6-1: 2019

EN 301 489-17: V3.2.4: 2020, Class B

EN 301 489-1: V2.2.3: 2019, Class B

FOR:

Compulab Ltd.

Desktop PC with Wi-Fi

Model: AIRTOP3

This report is in conformity with ISO/ IEC 17025. The "A2LA Accredited" symbol endorsement applies only to the tests and calibrations that are listed in the scope of Hermon Laboratories accreditation. The test results relate only to the items tested. This test report shall not be reproduced in any form except in full with the written approval of Hermon Laboratories Ltd.

Table of contents

1	Applicant information	3
2	Equipment under test attributes	3
3	Manufacturer information	3
4	Test details	3
5	Tests summary	4
6	EUT description	5
6.1	General information	5
6.2	EUT parts	5
6.3	Ports and lines	5
6.4	Auxiliary equipment	5
6.5	Operating frequencies	5
6.6	Test configuration	6
6.7	Acceptance criteria	9
7	Emissions tests according to FCC 47CFR part 15 subpart B and ICES-003 requirements	10
7.1	Conducted emissions	10
7.2	Radiated emission measurements	14
8	Emissions tests according to EN 55032, EN 61000-6-3, AS/NZS CISPR 32 and EN 301 489-17/1 requirements	20
8.1	Conducted emission measurements from AC mains power port	20
8.2	Conducted emission measurements at wired network port	24
8.3	Radiated emission measurements	27
8.4	Harmonic current emissions at AC mains input port	32
8.5	Voltage fluctuations and flicker at AC mains input port	35
9	Immunity tests according to EN 55035, EN IEC 61000-6-2 and EN 301 489-171 requirements	38
9.1	Immunity to electrostatic discharge (ESD)	38
9.2	Continuous RF electromagnetic field disturbances, swept and spot tests	42
9.3	Conducted immunity to electrical fast transient/ burst (EFT/ B)	45
9.4	Conducted immunity to voltage surges	49
9.5	Immunity to continuous induced RF disturbances	52
9.6	Immunity to power frequency magnetic fields	56
9.7	Immunity to voltage dips and short interruptions	59
10	APPENDIX A Test equipment and ancillaries used for tests	62
11	APPENDIX B Test laboratory description	64
12	APPENDIX C Abbreviations and acronyms	65
13	APPENDIX D Test equipment correction factors	66
14	APPENDIX E Measurement uncertainties	76
15	APPENDIX F Specification references	78

1 Applicant information

Client name: CompuLab Ltd.
Address: HaYetzira street. 17, "Mordot HaCarmel" Industrial park, P.O.Box 687, Yokneam Ilit 20692, Israel
Telephone: +972 4829 0142
Fax: +972 4829 0180
E-mail: dimitry@compulab.co.il
Contact name: Mr. Dimitry Katkov

2 Equipment under test attributes

Product name: Desktop PC with Wi-Fi
Trade Mark: 
Model: AIRTOP3
Part number: AIRTOP3-C4900-D64-HS4X1T-W-X10-FMAT3-ACI
Serial number: 1200724-00001
Hardware version: 1.0
Software release: Microsoft Win10
Receipt date: 13-Sep-20

3 Manufacturer information

Manufacturer name: CompuLab Ltd.
Address: HaYetzira street. 17, "Mordot HaCarmel" Industrial park, P.O.Box 687, Yokneam Ilit 20692, Israel
Telephone: +972 4829 0142
Fax: +972 4829 0180
E-mail: dimitry@compulab.co.il
Contact name: Mr. Dimitry Katkov

4 Test details

Project ID: 40652
Location: Hermon Laboratories Ltd. P.O. Box 23, Binyamina 3055001, Israel
Test started: 13-Sep-20
Test completed: 16-Nov-20
Test specifications: FCC 47CFR part 15: 2019, subpart B, Class B
ICES-003: 2017 Issue 6, Class B
AS/NZS CISPR 32: 2015, Class B
EN 55032: 2015, Class B
EN 61000-3-2: 2014
EN 61000-3-3: 2013
EN 55035: 2017
EN 61000-6-3: 2007 + A1 (11) + AC(12)
EN 61000-6-1: 2007
EN IEC 61000-6-1: 2019
EN 301 489-17: V3.2.4: 2020, Class B
EN 301 489-1: V2.2.3: 2019, Class B



5 Tests summary

Test	Status
FCC 47 CFR part 15, subpart B	
FCC 47 CFR, Section 15.107, Class B, AC power lines conducted emissions	Pass
FCC 47 CFR, Section 15.109, Class B, Radiated emissions	Pass
ICES-003	
ICES-003, Section 6.1, Class B, AC power lines conducted emissions	Pass
ICES-003, Section 6.2, Class B, Radiated emissions	Pass
EN 55032 / AS/NZS CISPR 32	
Section 5, Annex A.3, Class B, Conducted emissions from AC mains power ports	Pass
Section 5, Annex A.3, Class B, Conducted emissions from wired network port	Pass
Section 5, Annex A.2, Class B, Radiated emissions	Pass
Section 5, Annex A.3, Class B, Conducted emissions of voltages at tuner and modulator ports	Not required
EN 61000-3-2	
Harmonic current emissions	Pass
EN 61000-3-3	
Voltage fluctuations and flicker	Pass
EN 55035	
Immunity to electrostatic discharge (ESD)	Pass
Continuous RF electromagnetic field disturbances, swept and spot tests	Pass
Conducted immunity to electrical fast transients/ bursts (EFT/ B)	Pass
Conducted immunity to voltage surges	Pass
Immunity to continuous induced RF disturbances	Pass
Radiated immunity to power frequency magnetic field	Pass
Conducted immunity to voltage dips and short interruptions	Pass
Immunity to conducted broadband impulsive disturbances	Not required
EN 61000-6-3	
Conducted emission measurements at AC mains power port	Pass
Conducted emission measurements at DC power port	Not required
Conducted emission measurements at wired network port	Pass
Radiated emission measurements	Pass
EN IEC 61000-6-1	
Immunity to electrostatic discharge (ESD)	Pass
Radiated immunity to radio frequency electromagnetic field	Pass
Conducted immunity to electrical fast transients/ bursts (EFT/ B)	Pass
Conducted immunity to voltage surges	Pass
Conducted immunity to disturbances induced by radio frequency field	Pass
Radiated immunity to power frequency magnetic field	Pass
Conducted immunity to voltage dips and short interruptions	Pass
EN 301 489-17/1	
Conducted emission measurements at AC mains input port, Class B	Pass
Conducted emission measurements at DC power input/output port	Not required
Conducted emission measurements at wired network port, Class B	Pass
Radiated emission measurements, Class B	Pass
Harmonic current emissions at AC mains input port	Pass
Voltage fluctuations and flicker at AC mains input port	Pass
Immunity to electrostatic discharge (ESD)	Pass
Radiated immunity to radio frequency electromagnetic field	Pass
Conducted immunity to electrical fast transients/ bursts (EFT/ B)	Pass
Conducted immunity to voltage surges	Pass
Conducted immunity to disturbances induced by radio frequency field	Pass
Immunity to transients and surges in the vehicular environment	Not required
Conducted immunity to voltage variations, dips and short interruptions	Pass

Testing was completed against all relevant requirements of the test standard. The results obtained indicate that the product under test complies in full with the requirements tested.

The test results relate only to the items tested. Pass/ fail decision was based on nominal values.

	Name and Title	Date	Signature
Tested by:	Mr. B. Attar, test engineer	October 1, 2020	
Reviewed by:	Ms. N. Averin, certification engineer	November 23, 2020	
Approved by:	Mr. S. Samokha, Technical Manager, EMC and Radio	December 7, 2020	



6 EUT description

Note: The following data in this clause is provided by the customer and represents his sole responsibility.

6.1 General information

The EUT is a Desktop PC, which incorporates Wi-Fi module. The EUT is powered from AC mains via AC/DC adapter.

6.2 EUT parts

Description	Manufacturer	Model or P/N
Wi-Fi module	Intel Corp.	8260NGW, FCC ID: PD98260NG
AC/DC adapter	EDAC	EA13001N-190

6.3 Ports and lines

Port type	Port description	Connected		Qty.	Cable type	Cable length	Indoor / outdoor
		From	To				
Power	AC power	AC/DC adapter	AC mains	1	Unshielded	1.8 m	Indoor
Power	19 VDC power	EUT	AC/DC adapter	1	Unshielded	1 m*	Indoor
Wired network	Ethernet (LAN 1/2)	EUT	Loop	2	FTP	5 m**	Indoor
Signal	Audio IN	EUT	Microphone	1	Shielded	2 m*	Indoor
Signal	Audio OUT	EUT	Stereo Headset	1	Shielded	2 m*	Indoor
Signal	HDMI 1	EUT	Monitor	1	Shielded	2 m*	Indoor
Signal	HDMI 2	EUT	Fit-headless display simulator	1	Shielded	2 m*	Indoor
RF	Wi-Fi	EUT	Wi-Fi antenna	1	NA	NA	Indoor
Signal	RS-232	EUT	Loopback	1	Shielded	2 m*	Indoor
Signal	USB 2.0	EUT	Loopback plug	5	Shielded	2 m*	Indoor
Signal	USB 3.0	EUT	Loopback plug	2	Shielded	0.3 m*	Indoor
Signal	USB	EUT	SSD card	2	NA	NA	Indoor
Signal	USB	EUT	Keyboard	1	Shielded	2 m*	Indoor
Signal	USB	EUT	Mouse	1	Shielded	2 m*	Indoor

* Always shorter than 3 m.

** Always not longer than 30 m.

6.4 Auxiliary equipment

Description	Manufacturer	Model number
Combined keyboard and mouse with dongle	TEAC	SMX-20
Monitor	Asus	VE248H
Wireless-G Access Point (Wi-Fi)	Linksys	WAP54G
DHCP Server	CompuLab	FitPC-2
Stereo Headset	JVC	HA-RX300
Microphone	Silverline	NA

6.5 Operating frequencies

Source	Frequency, MHz					
Clock	0.032	25	48	100	500	2500
Wi-Fi	2402-2482	5150	---	---	---	---

6.6 Test configuration

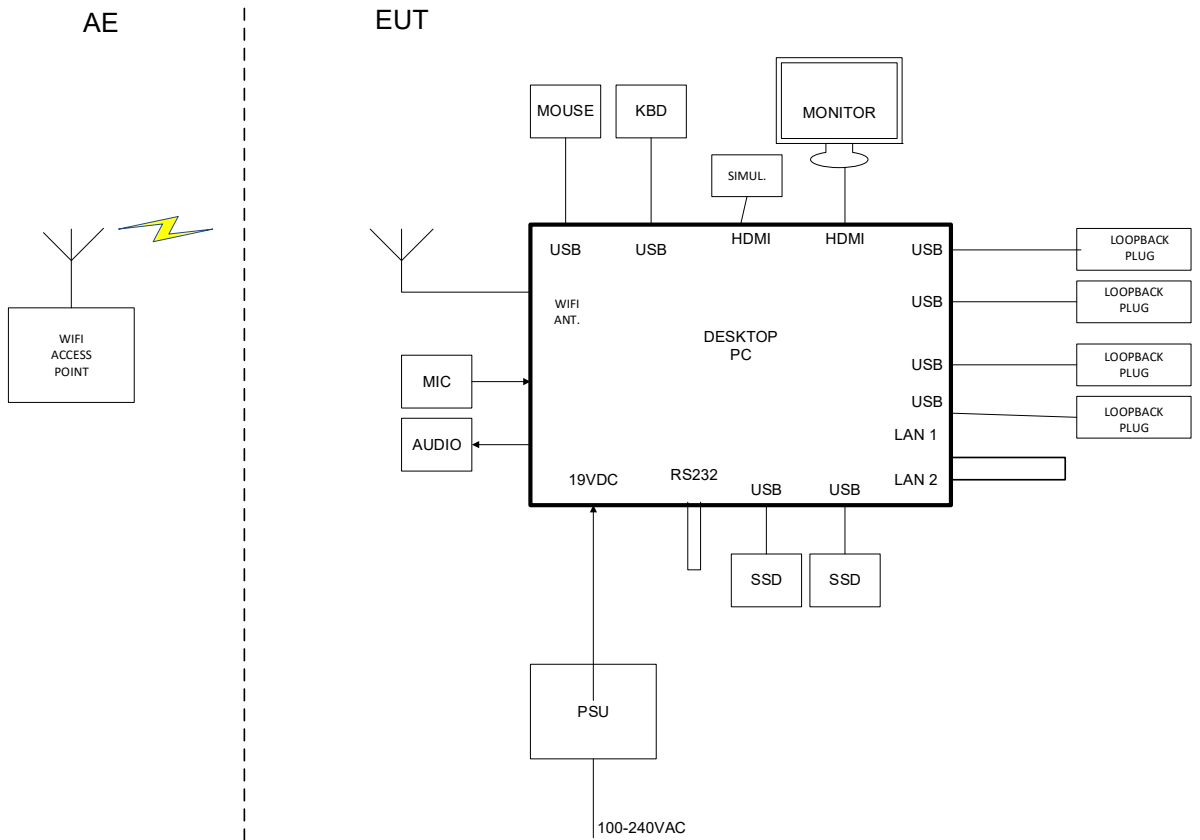

**6.6.1 General performance criteria of EN 55035, Section 8****6.6.1.1 Performance criterion A**

The equipment shall continue to operate as intended without operator intervention. No degradation of performance, loss of function or change of operating state is allowed below a performance level specified by the manufacturer when the equipment is used as intended. The performance level may be replaced by a permissible loss of performance. If the minimum performance level or the permissible performance loss is not specified by the manufacturer, then either of these may be derived from the product description and documentation, and by what the user may reasonably expect from the equipment if used as intended.

6.6.1.2 Performance criterion B

During the application of the disturbance, degradation of performance is allowed. However, no unintended change of actual operating state or stored data is allowed to persist after the test. After the test, the equipment shall continue to operate as intended without operator intervention; no degradation of performance or loss of function is allowed, below a performance level specified by the manufacturer, when the equipment is used as intended. The performance level may be replaced by a permissible loss of performance. If the minimum performance level (or the permissible performance loss), or recovery time, is not specified by the manufacturer, then either of these may be derived from the product description and documentation, and by what the user may reasonably expect from the equipment if used as intended.

6.6.1.3 Performance criterion C

Loss of function is allowed, provided the function is self-recoverable, or can be restored by the operation of the controls by the user in accordance with the manufacturer's instructions. A reboot or re-start operation is allowed. Information stored in non-volatile memory, or protected by a battery backup, shall not be lost.

6.6.2 Specific performance criteria of EN 55035, Annex F.3.3 (Networking functions)**6.6.2.1 Performance criterion A**

Where relevant, during the application of the test the network function shall, as a minimum, operate ensuring that:

- established connections shall be maintained throughout the application of the test;
- no change of operational state or corruption of stored data occurs;
- no increase in error rate above the figure defined by the manufacturer occurs. The manufacturer should select the most appropriate performance measurement criteria for the product or system, for example bit error rate, block error rate;
- no request for retry above the figure defined by the manufacturer;
- the data transmission rate does not reduce below the figure defined by the manufacturer;
- no protocol failure occurs;
- the audio noise level at a two-wire analogue interface (supporting telephony) shall satisfy the requirements of Table G.3. The audio level measurements shall be performed at the demodulated frequency of the disturbance using a narrowband filter with a 3 dB bandwidth of 100 Hz using the method defined in table clause G.1.4. See G.6.1.

As described in the example given in J.3.5 the networking function is monitored during testing using direct functions specified elsewhere in this document. If needed to verify the operation of the protocol, the following functions shall be verified as described in Table H.1 when performing the additional spot frequency tests contained in Clause 5:

- ability to establish a connection,
- ability to clear a connection.

Where an EUT has supervisory functions they shall not be affected. Elements that should be monitored include, but are not limited to:

- alarms,
- signalling lamps,
- printer output errors,
- network traffic rates,
- network monitor errors,
- measured network parameters.

6.6.2.2 Performance criterion B

Established connections shall be maintained throughout the test, or shall self-recover in a way and timescale that is imperceptible to the user. The error rate, request for retry and data transmission rates may be degraded during the application of the test. Degradation of the performance as described in criterion A is permitted, provided that the normal operation of the EUT is self-recoverable to the condition established prior to the application of the test. Where required, as defined in Clause 5, the acceptable operation of the function shall be verified at the completion of the test as described in Table H.1, by confirming the following:

- the EUT's ability to establish a connection,
- the EUT's ability to clear a connection.

During surge testing disconnection is allowed on the analogue/digital data port being tested. If the EUT is a supervisory equipment, it shall not impact the normal operation of the network being monitored. In addition, any supervisory functions impacted during the period of the test shall return to the state prior to the test. Elements to consider include:

- alarms,
- signalling lamps,
- printer output,
- network traffic rates,
- network monitoring.

6.6.2.3 Performance criterion C

Degradation of performance as described in criteria A and B is permitted provided that the normal operation of the EUT is self-recoverable to the condition immediately before the application of the test, or can be restored after the test by the operator.

**6.6.3 General performance criteria of EN IEC 61000-6-1, Section 4****6.6.3.1 Performance criterion A**

The EUT shall continue to operate as intended during and after the test. No degradation of performance or loss of function is allowed below a performance level specified by the manufacturer, when the EUT is used as intended. If the performance level is not specified by the manufacturer, this may be derived from the product description and documentation and what the user may reasonably expect from the equipment if used as intended.

6.6.3.2 Performance criterion B

The EUT shall continue to operate as intended after the test. No degradation of performance or loss of function is allowed below a performance level specified by the manufacturer, when the EUT is used as intended. The performance level may be replaced by a permissible loss of performance. However, during the test degradation of performance is allowed but no change of actual operating state or stored data is allowed. If the minimum performance level or the permissible performance loss is not specified by the manufacturer, either of these may be derived from the product description and documentation and what the user may reasonably expect from the equipment if used as intended.

6.6.3.3 Performance criterion C

Temporary loss of function is allowed during the test, provided the function is self-recoverable or can be restored by the operation of the controls.

6.6.4 Performance criteria according to EN 301-489-1**6.6.4.1 Performance criteria for continuous phenomena applied to transmitters and receivers, Section 6.1**

The EUT shall continue to operate as intended during and after the test. No degradation of performance or loss of function is allowed below a permissible performance level specified by the manufacturer, when the apparatus is used as intended. In some cases this permissible performance level may be replaced by a permissible loss of performance. During the test the EUT shall not unintentionally transmit or change its actual operating state and stored data. If the minimum performance level or the permissible performance loss is not specified by the manufacturer, either of these may be derived from the product description and documentation, and what the user may reasonably expect from the apparatus if used as intended.

6.6.4.2 Performance criteria for transient phenomena applied to transmitters and receivers, Section 6.2

The EUT shall continue to operate as intended after the test. No degradation of performance or loss of function is allowed below a performance level specified by the manufacturer, when the apparatus is used as intended. In some cases this permissible performance level may be replaced by a permissible loss of performance. During the EMC exposure to an electromagnetic phenomenon, degradation of performance is however allowed. No change of the actual mode of operation (e.g. unintended transmission) or stored data is allowed. If the minimum performance level or the permissible performance loss is not specified by the manufacturer, either of these may be derived from the product description and documentation, and what the user may reasonably expect from the apparatus if used as intended.

6.6.4.3 Performance criteria for equipment which does not provide a continuous communication link, Section 6.3

For radio equipment, which does not provide a continuous communication link, the performance criteria described in the clauses above are not appropriate, then the manufacturer shall declare, for inclusion in the test report, his own specification for an acceptable level of performance or degradation during and/or after the immunity tests. The performance specification shall be included in the product description and documentation.

6.6.4.4 Performance criteria for ancillary equipment tested on a stand alone basis, Section 6.4

If ancillary equipment is intended to be tested on a stand alone basis, the performance criteria described in the clauses above are not appropriate, then the manufacturer shall declare, for inclusion in the test report, his own specification for an acceptable level of performance or degradation during and/or after the immunity tests. The performance specification shall be included in the product description and documentation.

6.6.4.5 Performance criteria for voltage dips and interruptions, Section 9.7.3

For a voltage dip:

- for transmitters the performance criteria for transient phenomena for transmitter shall apply;
- for receivers the performance criteria for transient phenomena for receiver shall apply;
- for ancillary equipment the pass/failure criteria supplied by the manufacturer shall apply, unless the ancillary equipment is tested in connection with a receiver or transmitter, in which case the corresponding performance criteria above shall apply.

For a voltage interruption:

- in the case where the equipment is fitted with or connected to a battery back-up, the performance criteria for transient phenomena for transmitters or for receivers shall apply;
- in the case where the equipment is powered solely from the AC mains supply (without the use of a parallel battery back-up) volatile user data may have been lost and if applicable the communication link need to be maintained and lost functions should be recoverable by user or operator;
- no unintentional responses shall occur at the end of the test;
- in the event of loss of function(s) or in the event of loss the stored data, this fact shall be recorded in the test report;
- for ancillary equipment the pass/failure criteria supplied by the manufacturer shall apply, unless the ancillary equipment is tested in connection with a receiver or transmitter, in which case the corresponding performance criteria above shall apply.



6.6.5 Performance criteria according to EN 301-489-17

6.6.5.1 General performance criteria, Section 6.1

The performance criteria are:

- performance criteria A for immunity tests with phenomena of a continuous nature;
- performance criteria B for immunity tests with phenomena of a transient nature;
- performance criteria C for immunity tests with power interruptions exceeding a certain time.

6.6.5.2 Performance table, Section 6.2

Criteria	During test	After test
A	Shall operate as intended (see note) Shall be no loss of function Shall be no unintentional transmissions	Shall operate as intended Shall be no degradation of performance Shall be no loss of function Shall be no loss of critical stored data
B	May be loss of function	Functions shall be self-recoverable Shall operate as intended after recovering Shall be no loss of critical stored data
C	May be loss of function	Functions shall be recoverable by the operator Shall operate as intended after recovering Shall be no loss of critical stored data

NOTE 1: Operate as intended during the test allows a level of degradation in accordance with clause 6.2.2 of EN 301 489-17.

6.6.5.3 Performance criteria for continuous phenomena, Section 6.3

The performance criteria A shall apply.

Where the EUT is a transmitter in standby mode, unintentional transmission shall not occur during the test.

Where the EUT is a transceiver in receive mode, unintentional transmission shall not occur during the test.

6.6.5.4 Performance criteria for transient phenomena, Section 6.4

Performance criteria B shall apply, except for voltage dips of 100 ms and voltage interruptions of 5000 ms duration, for which performance criteria C shall apply.

Where the EUT is a transmitter in standby mode, unintentional transmission shall not occur as a result of the application of the test.

Where the EUT is a transceiver in receive mode, unintentional transmission shall not occur as a result of the application of the test.

6.7 Acceptance criteria

The EUT functions shall be maintained as intended throughout the test. The EUT shut down and "blue screen" are not allowed. Briefly blanking of monitor during ESD is allowed providing immediate self recovery of normal operation.



Test specification:	FCC 47 CFR, Section 15.107 / ICES-003, Section 6.1, Class B, AC power lines conducted emissions		
Test procedure:	ANSI C63.4, Section 7.3		
Test mode:	Compliance	Verdict:	PASS
Date(s):	13-Sep-20		
Temperature: 23 °C	Relative Humidity: 42 %	Air Pressure: 1010 hPa	Power: 120 VAC, 60 Hz
Remarks:			

7 Emissions tests according to FCC 47CFR part 15 subpart B and ICES-003 requirements

7.1 Conducted emissions

7.1.1 General

This test was performed to measure the common mode conducted emissions at the EUT power port. The specification test limits are given in Table 7.1.1.

Table 7.1.1 Limits for conducted emissions

Frequency, MHz	Class B limit, dB(μV)		Class A limit, dB(μV)	
	QP	AVRG	QP	AVRG
0.15 - 0.5	66 - 56*	56 - 46*	79	66
0.5 - 5.0	56	46	73	60
5.0 - 30	60	50	73	60

* - The limit decreases linearly with the logarithm of frequency.

7.1.2 Test procedure

7.1.2.1 The EUT was set up as shown in Figure 7.1.1 and the associated photograph, energized and the EUT performance was checked.

7.1.2.2 The measurements were performed at the EUT power terminals with the LISN connected to the EMI receiver in the frequency range referred to in Table 7.1.2. The unused coaxial connector of the LISN was terminated with 50 Ohm.

7.1.2.3 The position of the EUT cables was varied to find the highest emission.

7.1.2.4 The worst test results with respect to the limits were recorded in Table 7.1.2 and shown in the associated plots.



Test specification:	FCC 47 CFR, Section 15.107 / ICES-003, Section 6.1, Class B, AC power lines conducted emissions		
Test procedure:	ANSI C63.4, Section 7.3		
Test mode:	Compliance	Verdict:	PASS
Date(s):	13-Sep-20		
Temperature: 23 °C	Relative Humidity: 42 %	Air Pressure: 1010 hPa	Power: 120 VAC, 60 Hz
Remarks:			

Figure 7.1.1 Setup for conducted emission measurements, table-top EUT

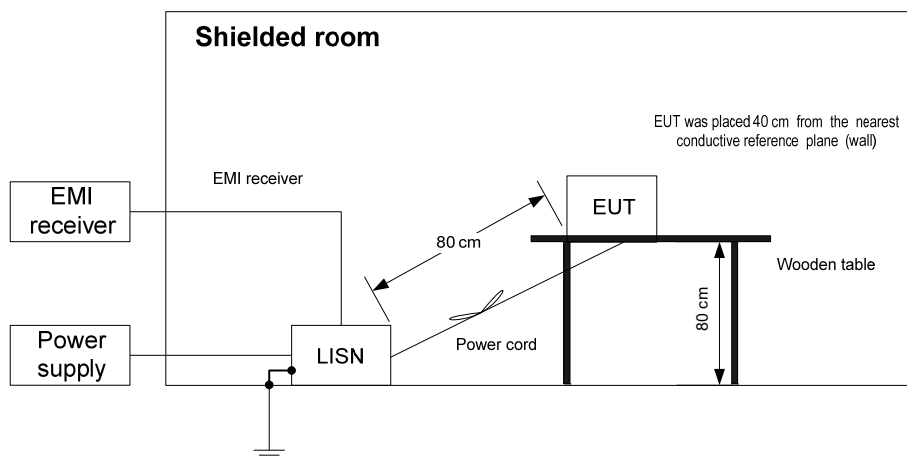

Photograph 7.1.1 Setup for conducted emission measurements





Test specification:	FCC 47 CFR, Section 15.107 / ICES-003, Section 6.1, Class B, AC power lines conducted emissions		
Test procedure:	ANSI C63.4, Section 7.3		
Test mode:	Compliance	Verdict:	PASS
Date(s):	13-Sep-20		
Temperature: 23 °C	Relative Humidity: 42 %	Air Pressure: 1010 hPa	Power: 120 VAC, 60 Hz
Remarks:			

Table 7.1.2 Conducted emission test results

LINE: AC mains input of AC/DC adapter
EUT SET UP: TABLE-TOP
TEST SITE: SHIELDED ROOM
DETECTORS USED: PEAK / QUASI-PEAK / AVERAGE
FREQUENCY RANGE: 150 kHz - 30 MHz
RESOLUTION BANDWIDTH: 9 kHz

Frequency, MHz	Quasi-peak			Average			Line ID	Verdict
	Measured emission, dB(μV)	Limit, dB(μV)	Margin, dB*	Measured emission, dB(μV)	Limit, dB(μV)	Margin, dB*		
4.40565	36.55	56.00	-19.45	21.94	46.00	-24.06	L1	Pass
5.64492	41.62	60.00	-18.38	26.14	50.00	-23.86		
6.21138	41.54	60.00	-18.46	27.14	50.00	-22.86		
24.58366	42.79	60.00	-17.21	42.42	50.00	-7.58		
0.30338	40.40	60.15	-19.75	24.54	50.15	-25.61	L2	Pass
18.58568	39.71	60.00	-20.29	30.24	50.00	-19.76		
24.58366	42.37	60.00	-17.63	41.95	50.00	-8.05		

*- Margin = Measured emission - specification limit.

Reference numbers of test equipment used

HL 0787	HL 3016	HL 5476	HL 5707				
---------	---------	---------	---------	--	--	--	--

Full description is given in Appendix A.

Test specification:	FCC 47 CFR, Section 15.107 / ICES-003, Section 6.1, Class B, AC power lines conducted emissions		
Test procedure:	ANSI C63.4, Section 7.3		
Test mode:	Compliance	Verdict:	PASS
Date(s):	13-Sep-20		
Temperature: 23 °C	Relative Humidity: 42 %	Air Pressure: 1010 hPa	Power: 120 VAC, 60 Hz
Remarks:			

Plot 7.1.1 Conducted emission measurements, AC mains input of AC/DC adapter

LINE: L1
LIMIT: QUASI-PEAK, AVERAGE
DETECTOR: PEAK

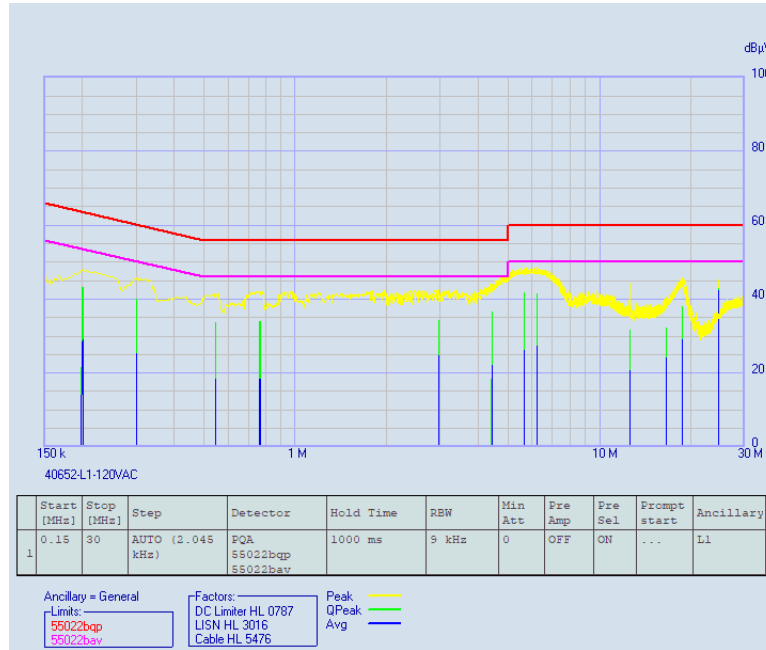

Plot 7.1.2 Conducted emission measurements, AC mains input of AC/DC adapter

LINE: L2
LIMIT: QUASI-PEAK, AVERAGE
DETECTOR: PEAK

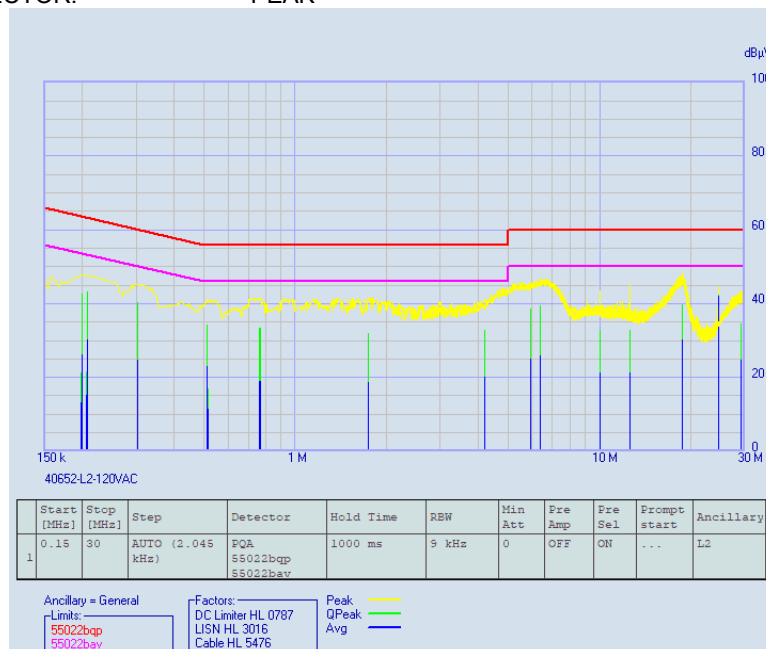



Test specification:	FCC 47 CFR, Section 15.109 / ICES-003, Section 6.2, Class B, Radiated emissions		
Test procedure:	ANSI C63.4, Section 8.3		
Test mode:	Compliance	Verdict:	PASS
Date(s):	01-Oct-20 – 16-Nov-20		
Temperature: 25 °C	Relative Humidity: 43 %	Air Pressure: 1007 hPa	Power: 120 VAC, 60 Hz
Remarks: The highest frequency used in the EUT is 5150 MHz; the test was performed in 30 – 26000 MHz range.			

7.2 Radiated emission measurements

7.2.1 General

This test was performed to measure radiated emissions from the EUT enclosure. The specification test limits are given in Table 7.2.1.

Table 7.2.1 Radiated emission test limits

Frequency, MHz	Class B limit, dB(μV/m)		Class A limit, dB(μV/m)	
	10 m distance	3 m distance	10 m distance	3 m distance
30 - 88	29.5*	40.0	39.0	49.5*
88 - 216	33.0*	43.5	43.5	54.0*
216 - 960	35.5*	46.0	46.4	56.9*
Above 960	43.5*	54.0	49.5	60.0*

* - The limit for a test distance other than specified was calculated using the inverse linear distance extrapolation factor as follows: $Lims_2 = Lims_1 + 20 \log(S_1/S_2)$, where S_1 and S_2 – the standard defined and the test distance respectively in meters.

7.2.2 Test procedure

7.2.2.1 30 – 1000 MHz range. The EUT was set up as shown in Figure 7.2.1 and the associated photographs, energized and the EUT performance was checked.

7.2.2.2 The measurements were performed in the semi anechoic chamber at 3 m test distance. The specified frequency range was investigated with the antenna connected to the EMI receiver. To find the highest emission the turntable was rotated 360° and the measuring antenna height was swept from 1 to 4 m in both, vertical and horizontal polarizations. The EUT cables position was varied to maximize emission.

7.2.2.3 1000 – 26000 MHz range. The EUT was set up as shown in Figure 7.2.2 and the associated photographs, energized and the EUT performance was checked.

7.2.2.4 The measurements were performed in the semi anechoic chamber at 3 m test distance. The specified frequency range was investigated with the antenna connected to the EMI receiver. To find the highest emission the turntable was rotated 360° and the measuring antenna height was swept from 1 to 4 m in both, vertical and horizontal polarizations. In order to stay within the 3 dB beamwidth while keeping the antenna height scanned from 1 to 4 m, a few sweeps with different antenna angles over the entire height were performed.

7.2.2.5 The worst test results with respect to the limits were recorded in Table 7.2.2 and shown in the associated plots.



Test specification:	FCC 47 CFR, Section 15.109 / ICES-003, Section 6.2, Class B, Radiated emissions		
Test procedure:	ANSI C63.4, Section 8.3		
Test mode:	Compliance	Verdict:	PASS
Date(s):	01-Oct-20 – 16-Nov-20		
Temperature: 25 °C	Relative Humidity: 43 %	Air Pressure: 1007 hPa	Power: 120 VAC, 60 Hz
Remarks: The highest frequency used in the EUT is 5150 MHz; the test was performed in 30 – 26000 MHz range.			

Figure 7.2.1 Setup for radiated emission measurements in semi anechoic chamber in 30 – 1000 MHz range, table-top EUT

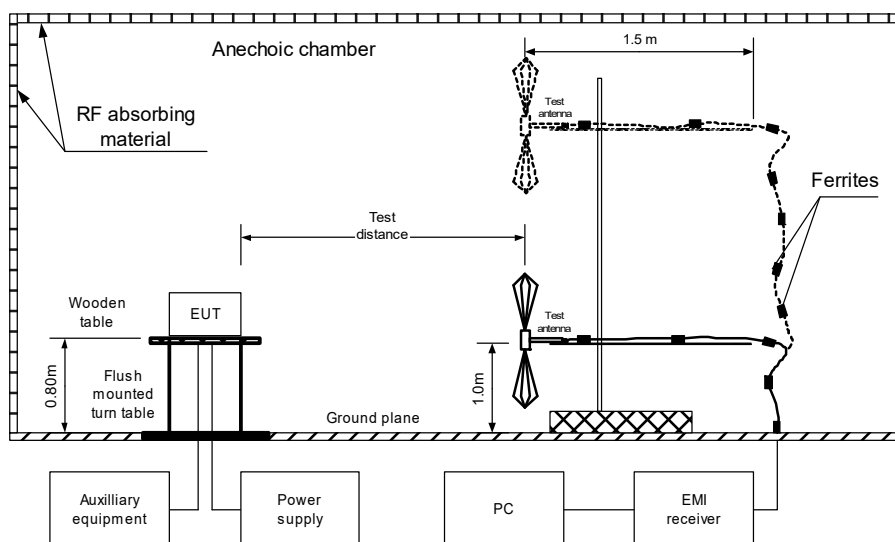
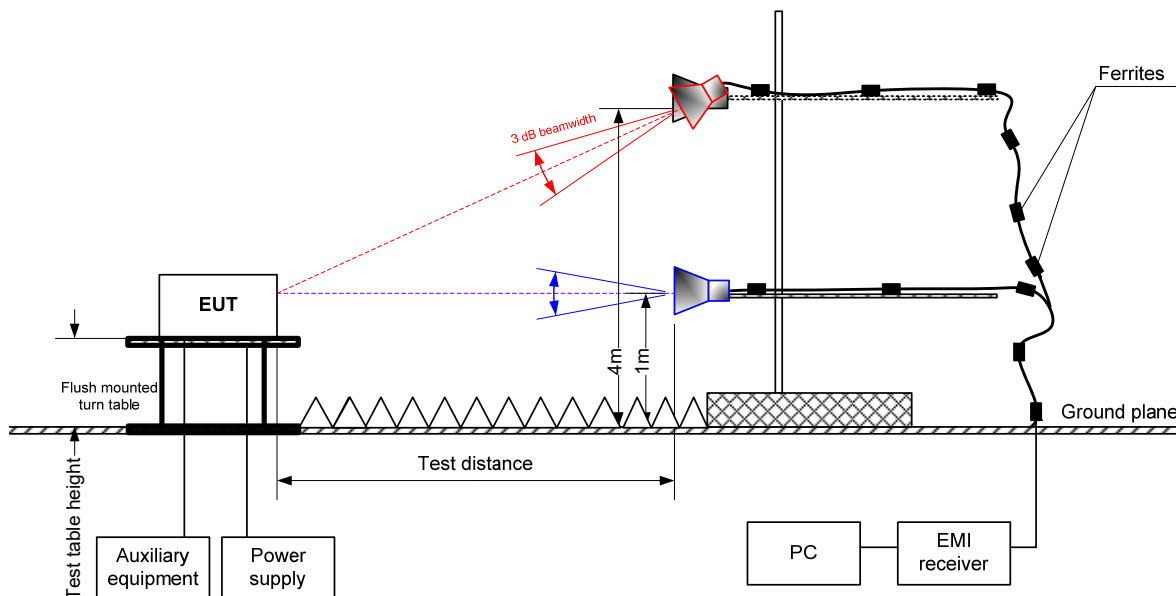

Figure 7.2.2 Setup for radiated emission measurements in semi anechoic chamber in 1000 – 26000 MHz range, table-top EUT





Test specification:	FCC 47 CFR, Section 15.109 / ICES-003, Section 6.2, Class B, Radiated emissions		
Test procedure:	ANSI C63.4, Section 8.3		
Test mode:	Compliance	Verdict:	PASS
Date(s):	01-Oct-20 – 16-Nov-20		
Temperature: 25 °C	Relative Humidity: 43 %	Air Pressure: 1007 hPa	Power: 120 VAC, 60 Hz
Remarks: The highest frequency used in the EUT is 5150 MHz; the test was performed in 30 – 26000 MHz range.			

Photograph 7.2.1 Setup for radiated emission measurements, general view



Photograph 7.2.2 Setup for radiated emission measurements, EUT cabling

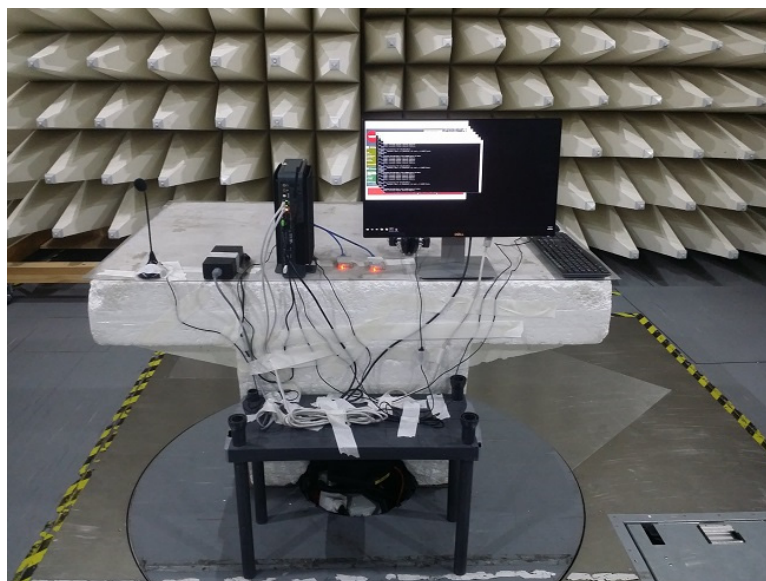



Test specification:	FCC 47 CFR, Section 15.109 / ICES-003, Section 6.2, Class B, Radiated emissions		
Test procedure:	ANSI C63.4, Section 8.3		
Test mode:	Compliance	Verdict:	PASS
Date(s):	01-Oct-20 – 16-Nov-20		
Temperature: 25 °C	Relative Humidity: 43 %	Air Pressure: 1007 hPa	Power: 120 VAC, 60 Hz
Remarks: The highest frequency used in the EUT is 5150 MHz; the test was performed in 30 – 26000 MHz range.			

Table 7.2.2 Radiated emission test results

EUT SET UP: TABLE-TOP
 TEST SITE: SEMI ANECHOIC CHAMBER
 TEST DISTANCE: 3 m
 FREQUENCY RANGE: 30 MHz – 1000 MHz
 DETECTORS USED: PEAK / QUASI-PEAK
 RESOLUTION BANDWIDTH: 120 kHz

Frequency, MHz	Peak emission, dB(µV/m)	Quasi-peak			Antenna polarization	Antenna height, m	Turn-table position**, degrees	Verdict
		Measured emission, dB(µV/m)	Limit, dB(µV/m)	Margin, dB*				
32.145	35.92	27.92	40.00	-12.08	Vertical	1.04	-99	Pass
128.636	47.44	39.02	43.50	-4.48	Horizontal	1.76	-99	
208.241	46.45	40.81	43.50	-2.69	Horizontal	1.31	138	
274.483	52.52	45.74	46.00	-0.26	Horizontal	1.02	138	
340.695	49.74	40.64	46.00	-5.36	Vertical	1.75	-77	
392.866	54.63	43.55	46.00	-2.45	Horizontal	1.02	-77	
836.882	51.49	44.86	46.00	-1.14	Horizontal	1.04	80	

FREQUENCY RANGE: 1000 MHz – 26000 MHz
 DETECTORS USED: PEAK / AVERAGE
 RESOLUTION BANDWIDTH: 1000 kHz

Frequency, MHz	Peak			Average			Antenna polarization	Antenna tilt, degrees	Antenna height, m	Turn-table position**, degrees	Verdict
	Measured emission, dB(µV/m)	Limit, dB(µV/m)	Margin, dB*	Measured emission, dB(µV/m)	Limit, dB(µV/m)	Margin, dB*					
No emissions were found.											Pass

*- Margin = Measured emission - specification limit.
 **- EUT front panel refers to 0 degrees position of turntable.

Reference numbers of test equipment used

HL 5670	HL 5669	HL 5085	HL 5288	HL 4360	HL 3903	HL 4933	HL 4956
---------	---------	---------	---------	---------	---------	---------	---------

Full description is given in Appendix A.



Test specification:	FCC 47 CFR, Section 15.109 / ICES-003, Section 6.2, Class B, Radiated emissions		
Test procedure:	ANSI C63.4, Section 8.3		
Test mode:	Compliance	Verdict:	PASS
Date(s):	01-Oct-20 – 16-Nov-20		
Temperature: 25 °C	Relative Humidity: 43 %	Air Pressure: 1007 hPa	Power: 120 VAC, 60 Hz
Remarks: The highest frequency used in the EUT is 5150 MHz; the test was performed in 30 – 26000 MHz range.			

Plot 7.2.1 Radiated emission measurements in 30 - 1000 MHz range, vertical and horizontal antenna polarization

TEST SITE: Semi anechoic chamber
TEST DISTANCE: 3 m

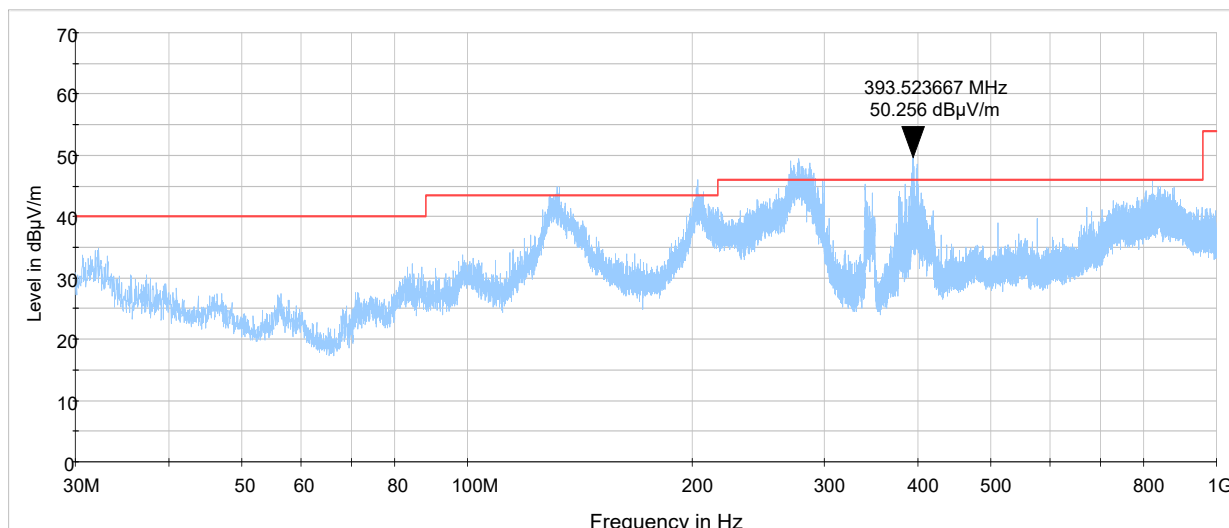

Plot 7.2.2 Radiated emission measurements in 1 - 13 GHz range, vertical and horizontal antenna polarization

TEST SITE: Semi anechoic chamber
TEST DISTANCE: 3 m

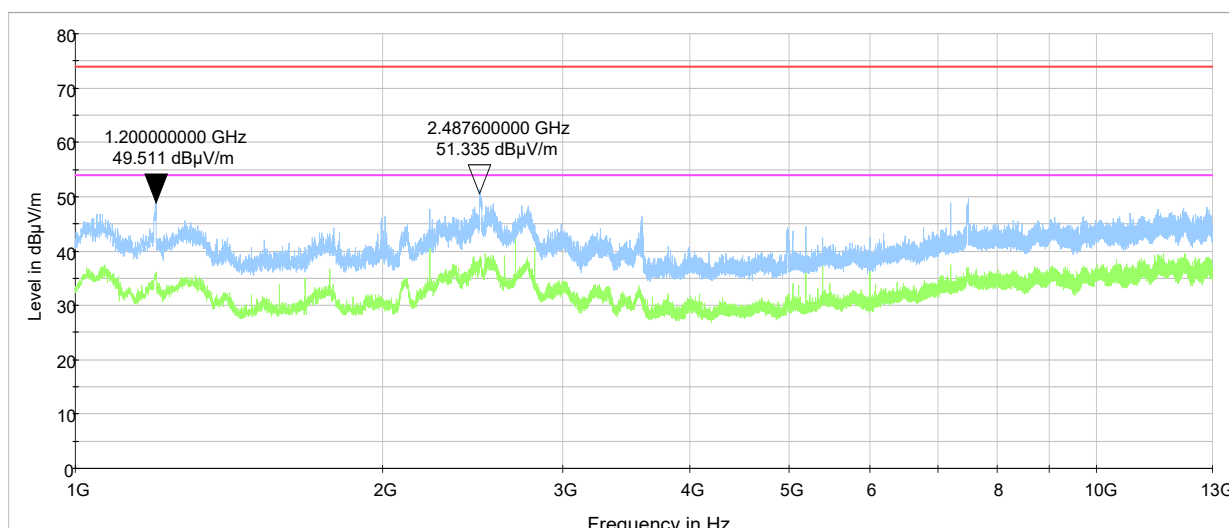



Test specification:	FCC 47 CFR, Section 15.109 / ICES-003, Section 6.2, Class B, Radiated emissions		
Test procedure:	ANSI C63.4, Section 8.3		
Test mode:	Compliance	Verdict:	PASS
Date(s):	01-Oct-20 – 16-Nov-20		
Temperature: 25 °C	Relative Humidity: 43 %	Air Pressure: 1007 hPa	Power: 120 VAC, 60 Hz
Remarks: The highest frequency used in the EUT is 5150 MHz; the test was performed in 30 – 26000 MHz range.			

Plot 7.2.2 Radiated emission measurements in 13 - 18 GHz range, vertical and horizontal antenna polarization

TEST SITE: Semi anechoic chamber
TEST DISTANCE: 3 m

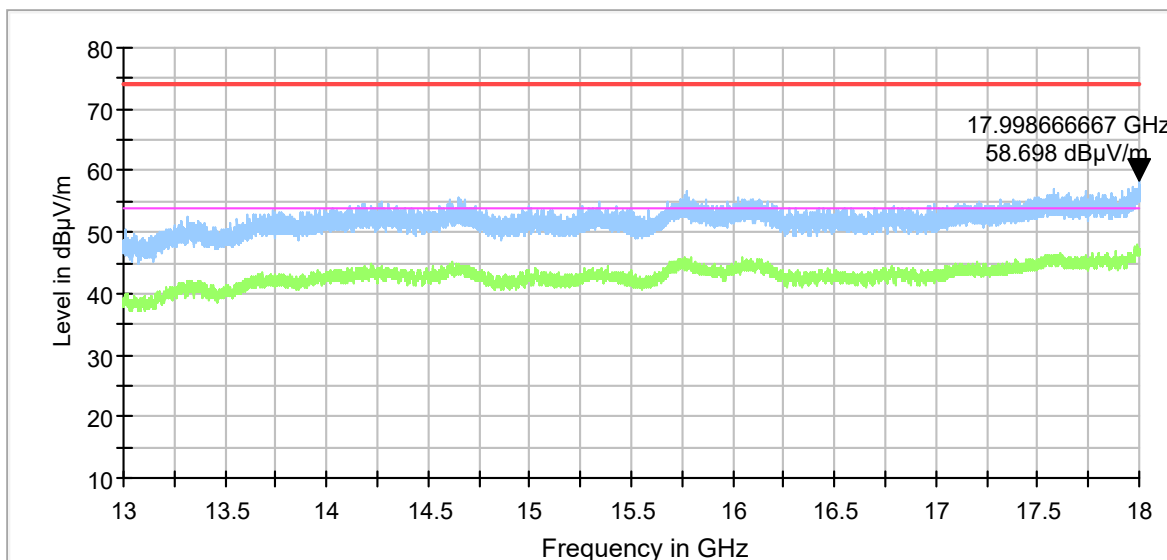

Plot 7.2.2 Radiated emission measurements in 18 - 26 GHz range, vertical and horizontal antenna polarization

TEST SITE: Semi anechoic chamber
TEST DISTANCE: 3 m

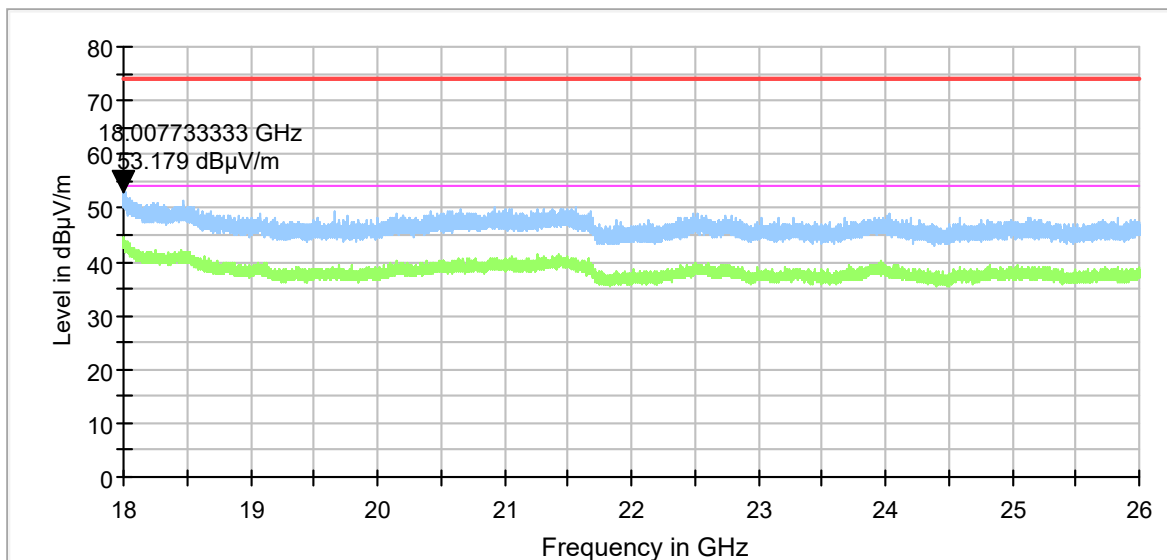



Test specification:	Conducted emission measurements at AC mains power port, Class B		
Test procedure:	EN 55032; AS/NZS CISPR 32, Annex A.3, Table A.7/8/9, Annex C.3, Section C.3.5; CISPR16-2-1; EN 301 489-1, Section 8.4, EN 61000-6-3, Table 2		
Test mode:	Compliance	Verdict:	PASS
Date(s):	13-Sep-20		
Temperature: 23 °C	Relative Humidity: 42 %	Air Pressure: 1010 hPa	Power: 230 VAC, 50 Hz
Remarks:			

8 Emissions tests according to EN 55032, EN 61000-6-3, AS/NZS CISPR 32 and EN 301 489-17/1 requirements

8.1 Conducted emission measurements from AC mains power port

8.1.1 General

This test was performed to measure common mode conducted emissions at the EUT power port. The specification test limits are given in Table 8.1.1.

Table 8.1.1 Limits for conducted emissions at AC mains power port

Frequency, MHz	Class B limit, dB(μ V)		Class A limit, dB(μ V)	
	QP	AVRG	QP	AVRG
0.15 - 0.5	66 - 56*	56 - 46*	79	66
0.5 - 5.0	56	46	73	60
5.0 - 30	60	50	73	60

* The limit decreases linearly with the logarithm of frequency.

8.1.2 Test procedure

8.1.2.1 The EUT was set up as shown in Figure 8.1.1 and the associated photograph, energized and the EUT performance was checked.

8.1.2.2 The measurements were performed at the EUT power terminals with the AMN, connected to the EMI receiver in the frequency range referred to in Table 8.1.2. The unused coaxial connector of the AMN was terminated with 50 Ohm.

8.1.2.3 The position of the EUT cables was varied to find the highest emission.

8.1.2.4 The worst test results with respect to the limits were recorded in Table 8.1.2 and shown in the associated plots.



Test specification:	Conducted emission measurements at AC mains power port, Class B		
Test procedure:	EN 55032; AS/NZS CISPR 32, Annex A.3, Table A.7/8/9, Annex C.3, Section C.3.5; CISPR16-2-1; EN 301 489-1, Section 8.4, EN 61000-6-3, Table 2		
Test mode:	Compliance	Verdict:	PASS
Date(s):	13-Sep-20		
Temperature: 23 °C	Relative Humidity: 42 %	Air Pressure: 1010 hPa	Power: 230 VAC, 50 Hz
Remarks:			

Figure 8.1.1 Setup for conducted emission measurements at AC mains power port, table-top EUT

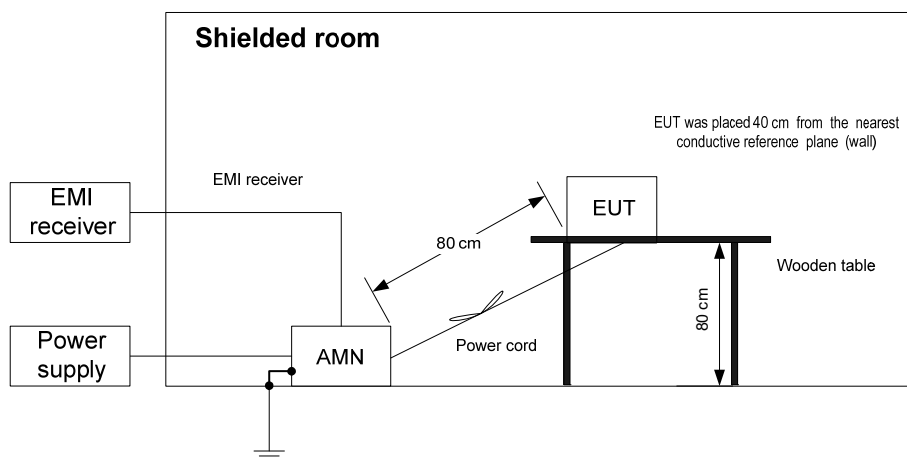

Photograph 8.1.1 Setup for conducted emission measurements at AC mains power port





Test specification:	Conducted emission measurements at AC mains power port, Class B		
Test procedure:	EN 55032; AS/NZS CISPR 32, Annex A.3, Table A.7/8/9, Annex C.3, Section C.3.5; CISPR16-2-1; EN 301 489-1, Section 8.4, EN 61000-6-3, Table 2		
Test mode:	Compliance	Verdict:	PASS
Date(s):	13-Sep-20		
Temperature: 23 °C	Relative Humidity: 42 %	Air Pressure: 1010 hPa	Power: 230 VAC, 50 Hz
Remarks:			

Table 8.1.2 Conducted emissions at AC mains power port test results

LINE: AC mains input of AC/DC adapter
EUT SET UP: TABLE-TOP
TEST SITE: SHIELDED ROOM
DETECTORS USED: PEAK / QUASI-PEAK / AVERAGE
FREQUENCY RANGE: 150 kHz - 30 MHz
RESOLUTION BANDWIDTH: 9 kHz

Frequency, MHz	Quasi-peak			Average			Line ID	Verdict
	Measured emission, dB(μV)	Limit, dB(μV)	Margin, dB*	Measured emission, dB(μV)	Limit, dB(μV)	Margin, dB*		
2.97210	35.02	56.00	-20.98	26.56	46.00	-19.44	L1	Pass
4.39951	36.18	56.00	-19.82	20.87	46.00	-25.13		
5.80034	41.50	60.00	-18.50	24.70	50.00	-25.30		
6.42611	41.17	60.00	-18.83	25.66	50.00	-24.34		
24.58366	43.01	60.00	-16.99	43.08	50.00	-6.92		
0.48129	37.21	56.32	-19.11	25.99	46.32	-20.33	L2	Pass
2.96801	32.47	56.00	-23.53	26.66	46.00	-19.34		
24.58162	42.54	60.00	-17.46	42.43	50.00	-7.57		

*- Margin = Measured emission - specification limit.

Reference numbers of test equipment used

HL 0787	HL 3016	HL 5476	HL 5707				
---------	---------	---------	---------	--	--	--	--

Full description is given in Appendix A.



Test specification:	Conducted emission measurements at AC mains power port, Class B		
Test procedure:	EN 55032; AS/NZS CISPR 32, Annex A.3, Table A.7/8/9, Annex C.3, Section C.3.5; CISPR16-2-1; EN 301 489-1, Section 8.4, EN 61000-6-3, Table 2		
Test mode:	Compliance	Verdict:	PASS
Date(s):	13-Sep-20		
Temperature: 23 °C	Relative Humidity: 42 %	Air Pressure: 1010 hPa	Power: 230 VAC, 50 Hz
Remarks:			

Plot 8.1.1 Conducted emissions at AC mains power port, AC mains input of AC/DC adapter

LINE: L1
LIMIT: QUASI-PEAK, AVERAGE
DETECTOR: PEAK

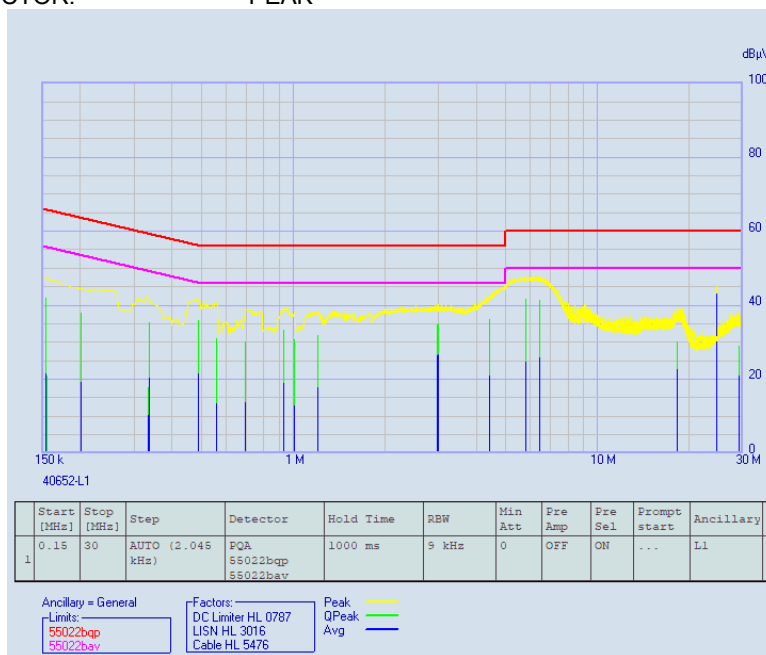

Plot 8.1.2 Conducted emissions at AC mains power port, AC mains input of AC/DC adapter

LINE: L2
LIMIT: QUASI-PEAK, AVERAGE
DETECTOR: PEAK

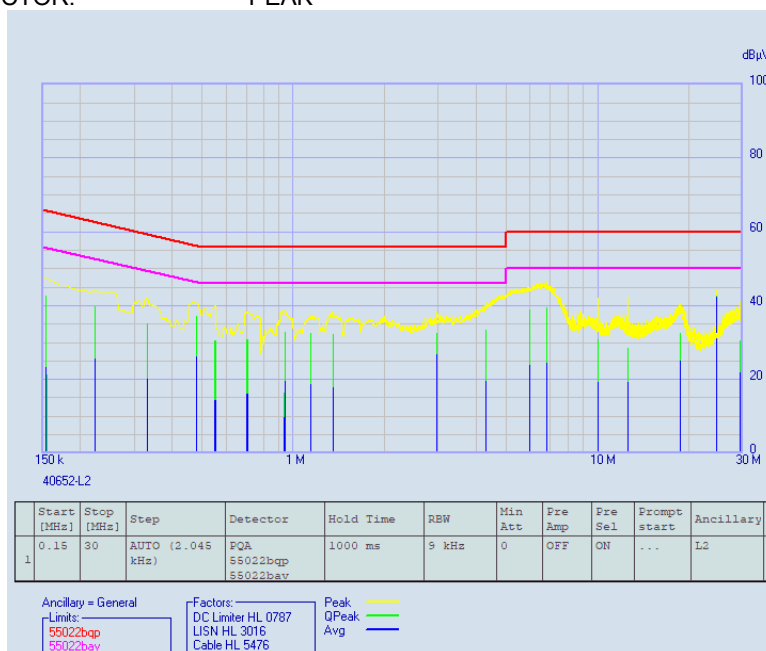



Test specification:	Conducted emission measurements at wired network port, Class B		
Test procedure:	EN 55032; AS/NZS CISPR 32, Annex A.3, Table A.10/A.11, Annex C.3, Section C.3.6, Annex C.4, Section C.4.1; CISPR 16-2-1; EN 301 489-1, Section 8.7, EN 61000-6-3, Table 4		
Test mode:	Compliance	Verdict:	PASS
Date(s):	13-Sep-20		
Temperature: 25 °C	Relative Humidity: 54 %	Air Pressure: 1001 hPa	Power: 230 VAC, 50 Hz
Remarks:			

8.2 Conducted emission measurements at wired network port

8.2.1 General

This test was performed to measure common mode conducted emissions at the EUT wired network port. The specification test limits are given in Table 8.2.1.

Table 8.2.1 Limits conducted emissions at wired network ports

Frequency, MHz	Class A				Class B			
	Voltage limits, dB(μ V)		Current limits, dB(μ A)		Voltage limits, dB(μ V)		Current limits, dB(μ A)	
	QP	AVRG	QP	AVRG	QP	AVRG	QP	AVRG
0.15 - 0.5	97 - 87*	84 - 74*	53 - 43*	40 - 30*	84 - 74*	74 - 64*	40 - 30*	30 - 20*
0.5 - 30	87	74	43	30	74	64	30	20

* - The limit decreases linearly with the logarithm of frequency.

8.2.2 Test procedure for conducted disturbance measurements with current probe and 150 Ohm termination

8.2.2.1 The EUT was set up as shown in Figure 8.2.1 and the associated photograph, energized and the EUT performance was checked.

8.2.2.2 The measurements were performed at the EUT wired network port with the current probe connected to the EMI receiver and 150-Ohm reference impedance provided between the outer surface of the shield and the reference ground in the specified frequency range as referred to in Table 8.2.2.

8.2.2.3 The position of the EUT cables was varied to find the highest emission.

8.2.2.4 The worst test results with respect to the limits were recorded in Table 8.2.2 and shown in the associated plot.



Test specification:	Conducted emission measurements at wired network port, Class B		
Test procedure:	EN 55032; AS/NZS CISPR 32, Annex A.3, Table A.10/A.11, Annex C.3, Section C.3.6, Annex C.4, Section C.4.1; CISPR 16-2-1; EN 301 489-1, Section 8.7, EN 61000-6-3, Table 4		
Test mode:	Compliance	Verdict:	PASS
Date(s):	13-Sep-20		
Temperature: 25 °C	Relative Humidity: 54 %	Air Pressure: 1001 hPa	Power: 230 VAC, 50 Hz
Remarks:			

Figure 8.2.1 Setup for conducted emission measurements at wired network ports with current probe

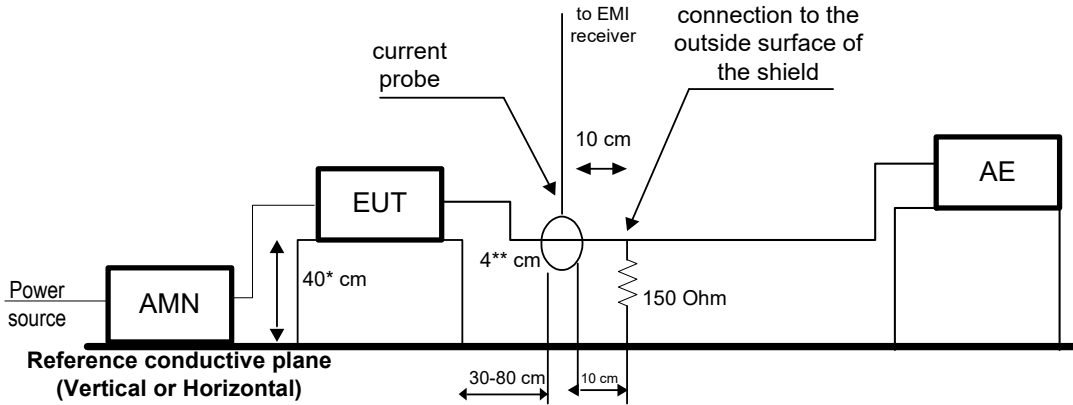

*Distance to the reference ground plane Vertical or Horizontal.

**Distance to the reference ground plane Vertical.

Photograph 8.2.1 Setup for conducted emission measurements at wired network port with current probe





Test specification:	Conducted emission measurements at wired network port, Class B		
Test procedure:	EN 55032; AS/NZS CISPR 32, Annex A.3, Table A.10/A.11, Annex C.3, Section C.3.6, Annex C.4, Section C.4.1; CISPR 16-2-1; EN 301 489-1, Section 8.7, EN 61000-6-3, Table 4		
Test mode:	Compliance	Verdict:	PASS
Date(s):	13-Sep-20		
Temperature: 25 °C	Relative Humidity: 54 %	Air Pressure: 1001 hPa	Power: 230 VAC, 50 Hz
Remarks:			

Table 8.2.2 Conducted emission at wired network port test results

LINE IDENTIFICATION: Ethernet (LAN)
 DATA TRANSMISSION SPEED: 100Mbps
 TEST COUPLING: CURRENT PROBE
 LINE TERMINATION: 150 Ohm
 EUT SET UP: TABLE TOP
 TEST SITE: SHIELDED ROOM
 DETECTORS USED: PEAK / QUASI-PEAK / AVERAGE
 FREQUENCY RANGE: 150 kHz – 30 MHz
 RESOLUTION BANDWIDTH: 9 kHz

Frequency, MHz	Quasi-peak			Average			Verdict
	Measured emission, dB(µA)	Limit, dB(µA)	Margin, dB*	Measured emission, dB(µA)	Limit, dB(µA)	Margin, dB*	
0.526	9.240	30.00	-20.760	0.400	20.00	-19.600	Pass
0.637	15.390	30.00	-14.610	5.120	20.00	-14.880	
3.537	7.230	30.00	-22.770	0.940	20.00	-19.060	
8.923	10.630	30.00	-19.370	7.440	20.00	-12.560	
23.310	7.290	30.00	-22.710	3.630	20.00	-16.370	
24.582	19.560	30.00	-10.440	19.490	20.00	-0.510	

*- Margin = Measured emission - specification limit.

Reference numbers of test equipment used

HL 0644	HL 1909	HL 3016	HL 5476				
---------	---------	---------	---------	--	--	--	--

Full description is given in Appendix A.

Plot 8.2.1 Conducted emission measurements at wired network port

LINE: Ethernet (LAN)
 LIMIT: QUASI-PEAK, AVERAGE
 DETECTOR: PEAK

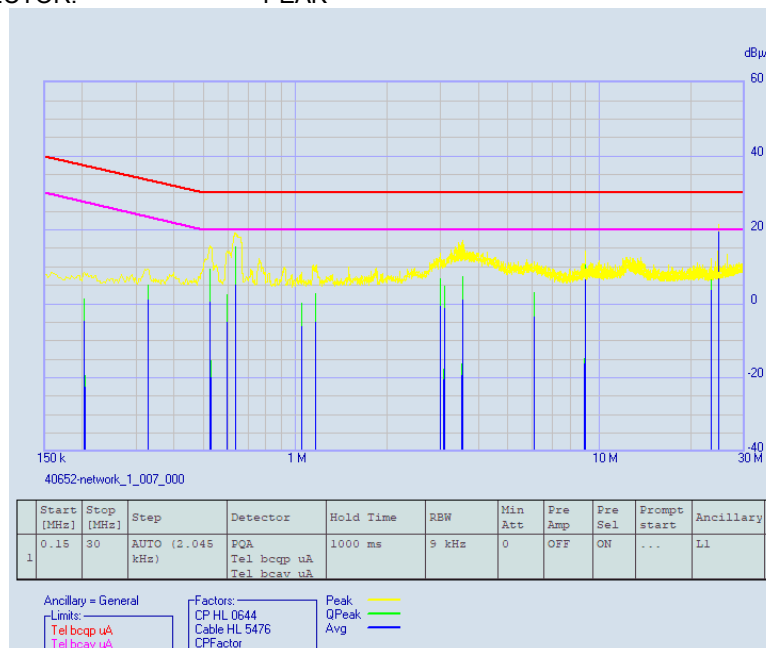



Test specification:	Radiated emissions, Class B		
Test procedure:	EN 55032; AS/NZS CISPR 32, Section 8, Table 1; Annex A.2, Table A.1/2/3/4/5, Annex C.3, Section C.3.4; CISPR 16-2-3; EN 61000-6-3, Table 1; EN 301 489-1, Section 8.2		
Test mode:	Compliance	Verdict:	PASS
Date(s):	13-Sep-20		
Temperature: 26 °C	Relative Humidity: 42 %	Air Pressure: 1010 hPa	Power: 230 VAC, 50 Hz
Remarks:			

8.3 Radiated emission measurements

8.3.1 General

This test was performed to measure radiated emissions from the EUT enclosure. The specification test limits are given in Table 8.3.1.

Table 8.3.1 Radiated emission limits

Frequency, MHz	Class B limit, dB(μ V/m)				Class A limit, dB(μ V/m)			
	Peak @3 m	Quasi-peak		Average @3 m	Peak @3 m	Quasi-peak		Average @3 m
		@10 m	@3 m			@10 m	@3 m	
30 - 230	—	30.0	40.0*	—	—	40.0	50.0*	—
230 - 1000	—	37.0	47.0*	—	—	47.0	57.0*	—
1000 - 3000	70	—	—	50	76	—	—	56
3000 - 6000	74	—	—	54	80	—	—	60

* The limit for 3 meters test distance was calculated by adding 10 dB to the 10 meters limit.

8.3.2 Test procedure

8.3.2.1 30 – 1000 MHz range. The EUT was set up as shown in Figure 8.3.1 and the associated photographs, energized and the EUT performance was checked.

8.3.2.2 The measurements were performed in the semi anechoic chamber at 3 m test distance. The specified frequency range was investigated with the antenna connected to the EMI receiver. To find the highest emission the turntable was rotated 360° and the measuring antenna height was swept from 1 to 4 m in both, vertical and horizontal polarizations. The EUT cables position was varied to maximize emission.

8.3.2.3 1000 – 6000 MHz range. The EUT was set up as shown in Figure 8.3.2 and the associated photographs, energized and the EUT performance was checked.

8.3.2.4 The measurements were performed in the semi anechoic chamber at 3 m test distance. The specified frequency range was investigated with the antenna connected to the EMI receiver. To find maximum radiation the turntable was rotated 360° and the measuring antenna was installed at fixed height pointed to the physical center of the EUT in both, vertical and horizontal polarizations.

8.3.2.5 The worst test results with respect to the limits were recorded in Table 8.3.2 and shown in the associated plots.



Test specification:	Radiated emissions, Class B		
Test procedure:	EN 55032; AS/NZS CISPR 32, Section 8, Table 1; Annex A.2, Table A.1/2/3/4/5, Annex C.3, Section C.3.4; CISPR 16-2-3; EN 61000-6-3, Table 1; EN 301 489-1, Section 8.2		
Test mode:	Compliance	Verdict:	PASS
Date(s):	13-Sep-20		
Temperature: 26 °C	Relative Humidity: 42 %	Air Pressure: 1010 hPa	Power: 230 VAC, 50 Hz
Remarks:			

Figure 8.3.1 Setup for radiated emission measurements in semi anechoic chamber below 1 GHz, table-top EUT

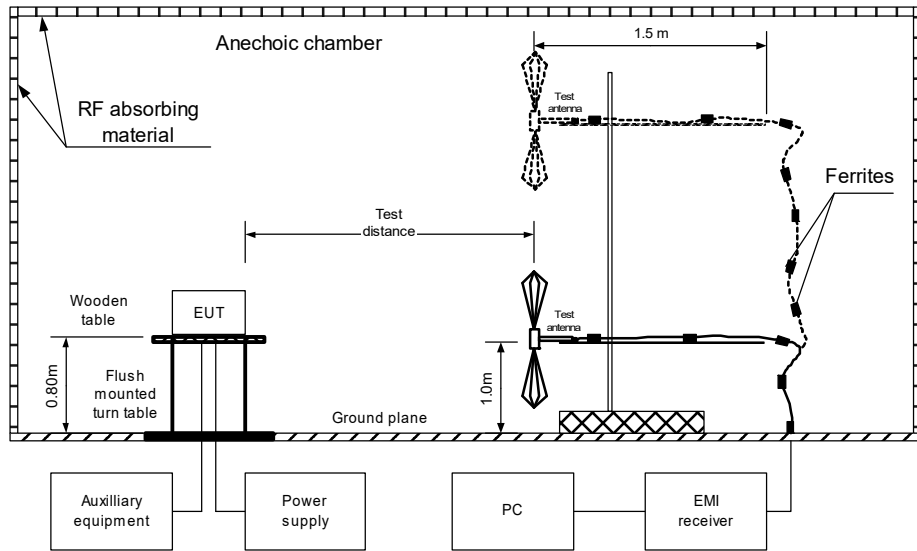
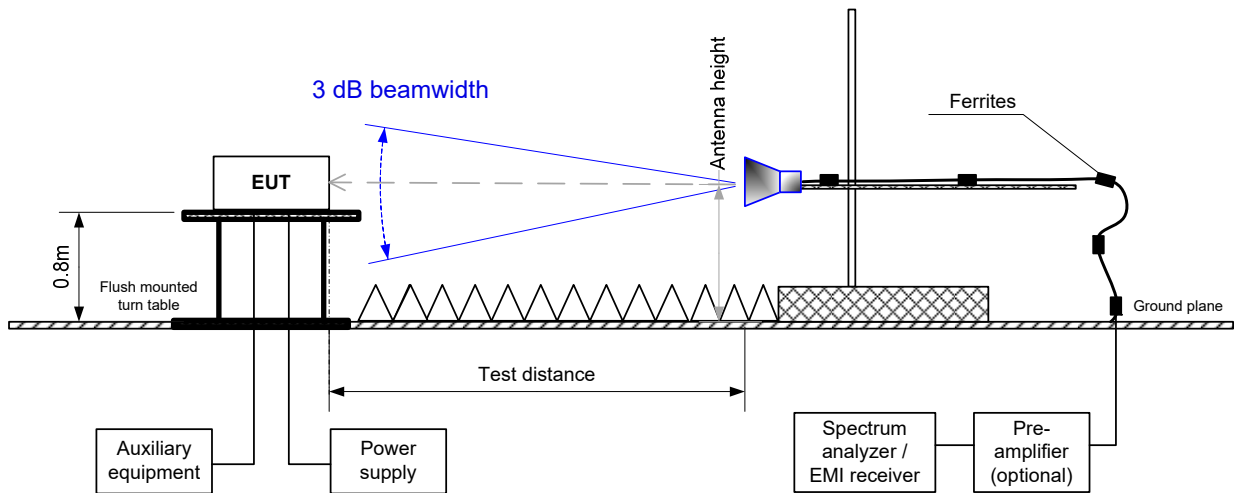

Figure 8.3.2 Setup for radiated emission measurements in semi anechoic chamber above 1 GHz, table-top EUT





Test specification:	Radiated emissions, Class B		
Test procedure:	EN 55032; AS/NZS CISPR 32, Section 8, Table 1; Annex A.2, Table A.1/2/3/4/5, Annex C.3, Section C.3.4; CISPR 16-2-3; EN 61000-6-3, Table 1; EN 301 489-1, Section 8.2		
Test mode:	Compliance	Verdict:	PASS
Date(s):	13-Sep-20		
Temperature: 26 °C	Relative Humidity: 42 %	Air Pressure: 1010 hPa	Power: 230 VAC, 50 Hz
Remarks:			

Photograph 8.3.1 Setup for radiated emission measurements, general view

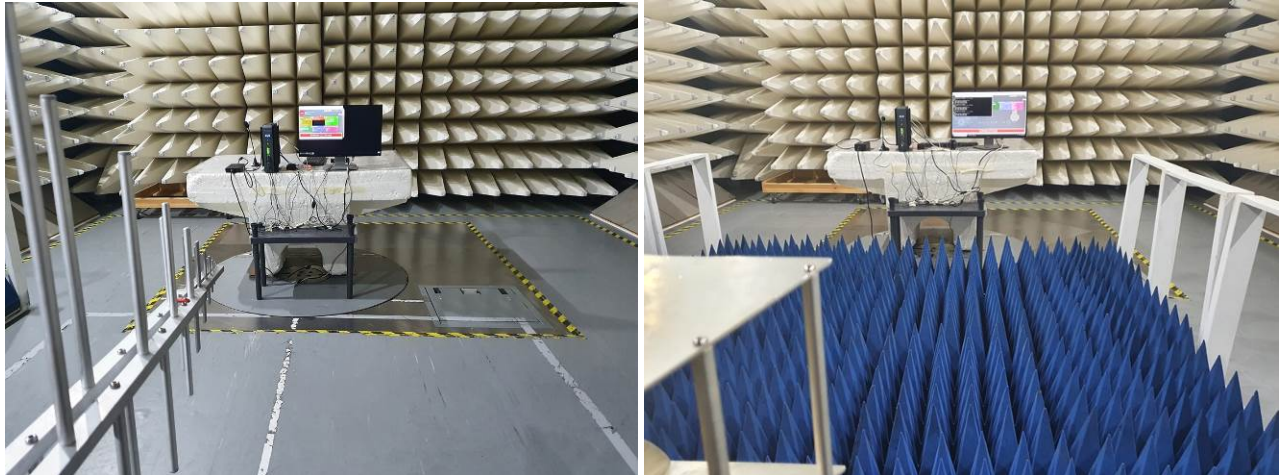

Photograph 8.3.2 Setup for radiated emission measurements, EUT cabling

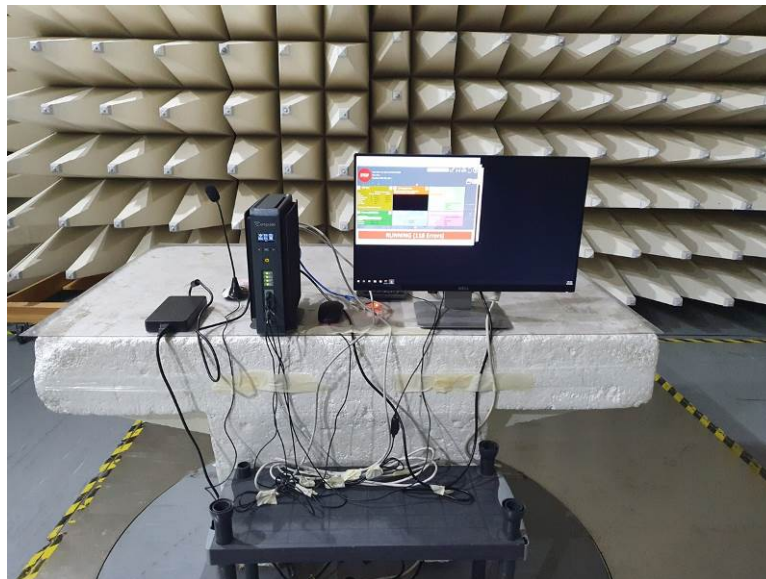



Test specification:	Radiated emissions, Class B		
Test procedure:	EN 55032; AS/NZS CISPR 32, Section 8, Table 1; Annex A.2, Table A.1/2/3/4/5, Annex C.3, Section C.3.4; CISPR 16-2-3; EN 61000-6-3, Table 1; EN 301 489-1, Section 8.2		
Test mode:	Compliance	Verdict:	PASS
Date(s):	13-Sep-20		
Temperature: 26 °C	Relative Humidity: 42 %	Air Pressure: 1010 hPa	Power: 230 VAC, 50 Hz
Remarks:			

Table 8.3.2 Radiated emission test results

EUT SET UP: TABLE-TOP
TEST SITE: SEMI ANECHOIC CHAMBER
TEST DISTANCE: 3 m
FREQUENCY RANGE: 30 MHz – 1000 MHz
DETECTORS USED: PEAK / QUASI-PEAK
RESOLUTION BANDWIDTH: 120 kHz

Frequency, MHz	Peak emission, dB(μV/m)	Quasi-peak			Antenna polarization	Antenna height, m	Turn-table position**, degrees	Verdict
		Measured emission, dB(μV/m)	Limit, dB(μV/m)	Margin, dB*				
204.941913	43.27	35.57	40.00	-4.43	Vertical	2.22	-167	Pass
216.016745	45.02	39.40	40.00	-0.60	Horizontal	1.33	-144	
287.982844	49.89	41.32	47.00	-5.68	Horizontal	1.02	-54	
340.582033	52.04	43.38	47.00	-3.62	Horizontal	1.00	-56	
814.968137	49.17	42.72	47.00	-4.28	Horizontal	1.00	60	
848.761541	48.90	41.98	47.00	-5.02	Horizontal	1.02	64	

FREQUENCY RANGE: 1000 MHz - 6000 MHz
DETECTORS USED: PEAK / AVERAGE
RESOLUTION BANDWIDTH: 1 MHz

Frequency, MHz	Peak			Average			Antenna polarization	Antenna height, m	Turn-table position**, degrees	Verdict
	Measured emission, dB(μV/m)	Limit, dB(μV/m)	Margin, dB*	Measured emission, dB(μV/m)	Limit, dB(μV/m)	Margin, dB*				
No emissions were found.										Pass

*- Margin = Measured emission - specification limit.

** - EUT front panel refers to 0 degrees position of turntable.

Reference numbers of test equipment used

HL 3903	HL 4360	HL 4933	HL 5288	HL 5669	HL 5670		
---------	---------	---------	---------	---------	---------	--	--

Full description is given in Appendix A.



Test specification:	Radiated emissions, Class B		
Test procedure:	EN 55032; AS/NZS CISPR 32, Section 8, Table 1; Annex A.2, Table A.1/2/3/4/5, Annex C.3, Section C.3.4; CISPR 16-2-3; EN 61000-6-3, Table 1; EN 301 489-1, Section 8.2		
Test mode:	Compliance	Verdict:	PASS
Date(s):	13-Sep-20		
Temperature: 26 °C	Relative Humidity: 42 %	Air Pressure: 1010 hPa	Power: 230 VAC, 50 Hz
Remarks:			

Plot 8.3.1 Radiated emission measurements in 30 - 1000 MHz range, vertical & horizontal antenna polarization

TEST SITE: Semi anechoic chamber
TEST DISTANCE: 3 m

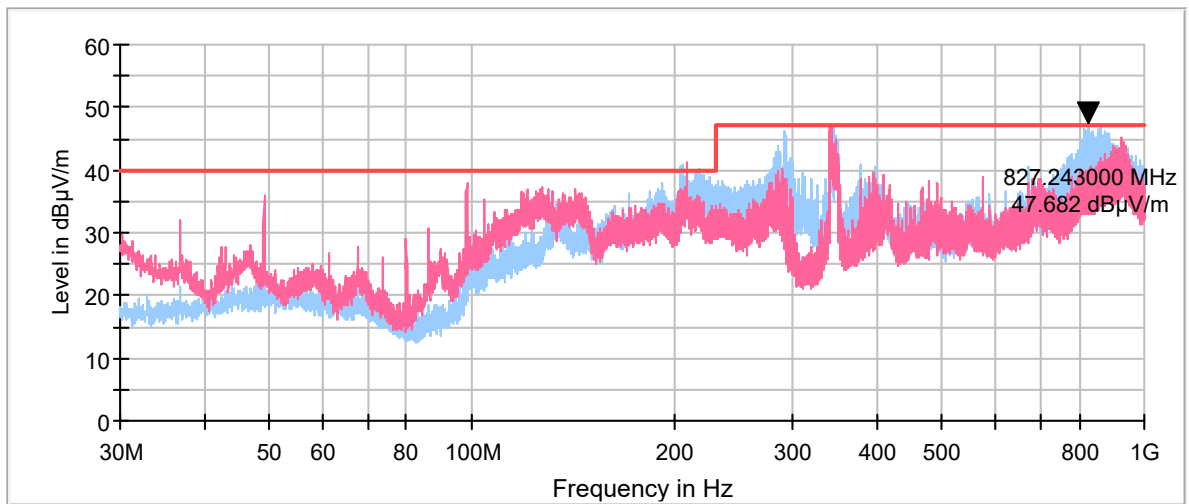

Plot 8.3.2 Radiated emission measurements in 1000 – 6000 MHz range, vertical & horizontal antenna polarization

TEST SITE: Semi anechoic chamber
TEST DISTANCE: 3 m

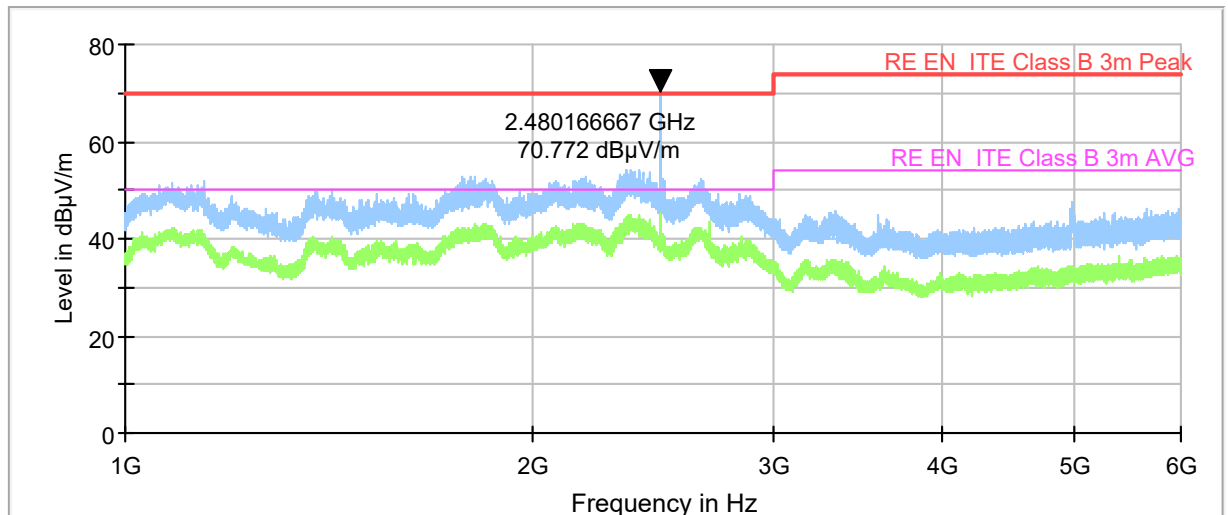



Test specification:	Harmonic current emissions at AC mains input port		
Test procedure:	EN 301 489-1, Section 8.5, EN 61000-3-2; EN 61000-6-3, Table 2		
Test mode:	Compliance	Verdict:	PASS
Date(s):	14-Sep-20		
Temperature: 24 °C	Relative Humidity: 53 %	Air Pressure: 1010 hPa	Power: 230 VAC, 50 Hz
Remarks:			

8.4 Harmonic current emissions at AC mains input port

8.4.1 General

This test was performed to measure the harmonic currents injected into the public supply system. The specification test limits are given in Table 8.4.1.

Table 8.4.1 Harmonic current emission limits

Harmonic order, n	Equipment class A	Equipment class D	
	Maximum permissible harmonic current, A	Maximum permissible harmonic current per watt, mA/W	Maximum permissible harmonic current, A
Odd harmonics			
3	2.30	3.4	2.30
5	1.14	1.9	1.14
7	0.77	1.0	0.77
9	0.40	0.5	0.40
11	0.33	0.35	0.33
13	0.21	0.30	0.21
15 ≤ n ≤ 39	0.15 X 15/n	3.85/n	0.15 X 15/n
Even harmonics			
2	1.08	NA	
4	0.43		
6	0.30		
8 ≤ n ≤ 40	0.23 X 8/n		

8.4.2 Test procedure

- 8.4.2.1 The EUT was set up as shown in Figure 8.4.1 and the associated photograph, energized and the EUT performance was checked.
- 8.4.2.2 The EUT was operated under normal operating and load conditions.
- 8.4.2.3 The harmonic currents for transitory and steady states conditions were measured with the computerized setup. The test results are provided in the associated tables.



Test specification:	Harmonic current emissions at AC mains input port		
Test procedure:	EN 301 489-1, Section 8.5, EN 61000-3-2; EN 61000-6-3, Table 2		
Test mode:	Compliance	Verdict:	PASS
Date(s):	14-Sep-20		
Temperature: 24 °C	Relative Humidity: 53 %	Air Pressure: 1010 hPa	Power: 230 VAC, 50 Hz
Remarks:			

Figure 8.4.1 Setup for harmonic current emissions test

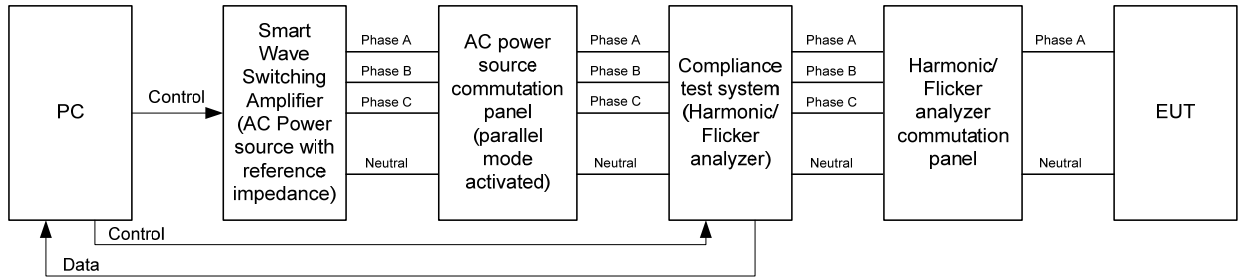

Photograph 8.4.1 Setup for harmonic current emissions test





Test specification:	Harmonic current emissions at AC mains input port		
Test procedure:	EN 301 489-1, Section 8.5, EN 61000-3-2; EN 61000-6-3, Table 2		
Test mode:	Compliance	Verdict:	PASS
Date(s):	14-Sep-20		
Temperature: 24 °C	Relative Humidity: 53 %	Air Pressure: 1010 hPa	Power: 230 VAC, 50 Hz
Remarks:			

Table 8.4.2 Fluctuating harmonics summary results

Test Result: Pass
 Highest parameter values during test:
 V_RMS (Volts): 233.32
 I_Peak (Amps): 1.989
 I_Fund (Amps): 0.652
 Power (Watts): 147.7

Source qualification: Normal
 Frequency(Hz): 50.00
 I_RMS (Amps): 0.690
 Crest Factor: 3.158
 Power Factor: 0.917

Table 8.4.3 Fluctuating harmonics test results

Harm#	Harms(avg)	100%Limit	%of Limit	Harms(max)	150%Limit	%of Limit	Status
2	0.010	1.080	0.9	0.012	1.620	0.75	Pass
3	0.181	2.300	7.9	0.193	3.450	5.59	Pass
4	0.001	0.430	0.3	0.002	0.645	0.38	Pass
5	0.041	1.140	3.6	0.042	1.710	2.46	Pass
6	0.002	0.300	0.6	0.003	0.450	0.62	Pass
7	0.021	0.770	2.8	0.027	1.155	2.35	Pass
8	0.001	0.230	0.6	0.002	0.345	0.66	Pass
9	0.022	0.400	5.5	0.025	0.600	4.24	Pass
10	0.001	0.184	0.7	0.002	0.276	0.66	Pass
11	0.013	0.330	4.0	0.014	0.495	2.80	Pass
12	0.001	0.153	0.7	0.002	0.230	0.71	Pass
13	0.008	0.210	3.6	0.009	0.315	2.81	Pass
14	0.001	0.131	0.5	0.001	0.197	0.68	Pass
15	0.014	0.150	9.0	0.015	0.225	6.72	Pass
16	0.001	0.115	0.5	0.001	0.173	0.54	Pass
17	0.008	0.132	6.2	0.010	0.199	4.81	Pass
18	0.000	0.102	0.4	0.001	0.153	0.45	Pass
19	0.008	0.118	6.5	0.008	0.178	4.60	Pass
20	0.001	0.092	0.7	0.001	0.138	0.85	Pass
21	0.010	0.107	9.8	0.013	0.161	8.09	Pass
22	0.001	0.084	1.6	0.002	0.125	1.65	Pass
23	0.006	0.098	5.6	0.010	0.147	6.52	Pass
24	0.002	0.077	2.1	0.003	0.115	2.44	Pass
25	0.005	0.090	5.7	0.007	0.135	5.27	Pass
26	0.001	0.071	1.4	0.002	0.106	2.23	Pass
27	0.006	0.083	7.7	0.008	0.125	6.64	Pass
28	0.001	0.066	1.4	0.002	0.099	1.74	Pass
29	0.006	0.078	8.0	0.010	0.116	8.29	Pass
30	0.001	0.061	1.8	0.002	0.092	2.19	Pass
31	0.005	0.073	7.0	0.007	0.109	6.62	Pass
32	0.001	0.058	1.5	0.002	0.086	1.94	Pass
33	0.004	0.068	6.1	0.005	0.102	4.79	Pass
34	0.001	0.054	1.5	0.002	0.081	1.97	Pass
35	0.004	0.064	6.0	0.005	0.096	4.96	Pass
36	0.001	0.051	1.4	0.001	0.077	1.90	Pass
37	0.005	0.061	7.8	0.007	0.091	7.62	Pass
38	0.001	0.048	1.6	0.001	0.073	2.02	Pass
39	0.003	0.058	6.0	0.005	0.087	5.76	Pass
40	0.001	0.046	1.4	0.001	0.069	1.79	Pass

Reference numbers of test equipment used

HL 2364	HL 2417	HL 2666				
---------	---------	---------	--	--	--	--

Full description is given in Appendix A.



Test specification:	Voltage fluctuations and flicker at AC mains input port		
Test procedure:	EN 301 489-1, Section 8.6, EN 61000-3-3; EN 61000-6-3, Table 2		
Test mode:	Compliance	Verdict:	PASS
Date(s):	14-Sep-20		
Temperature: 23 °C	Relative Humidity: 46 %	Air Pressure: 1010 hPa	Power: 230 VAC, 50 Hz
Remarks:			

8.5 Voltage fluctuations and flicker at AC mains input port

8.5.1 General

This test was performed to measure the voltage fluctuations and flicker impressed on the public low-voltage system at the supply terminals of the EUT. The specification test limits are given in Table 8.5.1.

Table 8.5.1 Voltage fluctuations and flicker limits

No.	Criteria
1.	The value of short term flicker shall not be greater than 1.0
2.	The value of long term flicker shall not be greater than 0.65
3.	The relative steady state voltage shall not exceed 3.3%
4.	The maximum relative voltage change shall not exceed 4%
5.	The value of the relative voltage change waveform shall not exceed 3.3% for more than 500 ms.

8.5.2 Test procedure

8.5.2.1 The EUT was set up as shown in Figure 8.5.1 and the associated photograph, energized and the EUT performance was checked.

8.5.2.2 The EUT was operated under normal operating and load conditions.

8.5.2.3 The voltage fluctuations and flickers for transitory and steady states conditions were measured with the computerized setup. The test results are provided in the associated table.



Test specification:	Voltage fluctuations and flicker at AC mains input port		
Test procedure:	EN 301 489-1, Section 8.6, EN 61000-3-3; EN 61000-6-3, Table 2		
Test mode:	Compliance	Verdict:	PASS
Date(s):	14-Sep-20		
Temperature: 23 °C	Relative Humidity: 46 %	Air Pressure: 1010 hPa	Power: 230 VAC, 50 Hz
Remarks:			

Figure 8.5.1 Setup for voltage fluctuations and flicker test

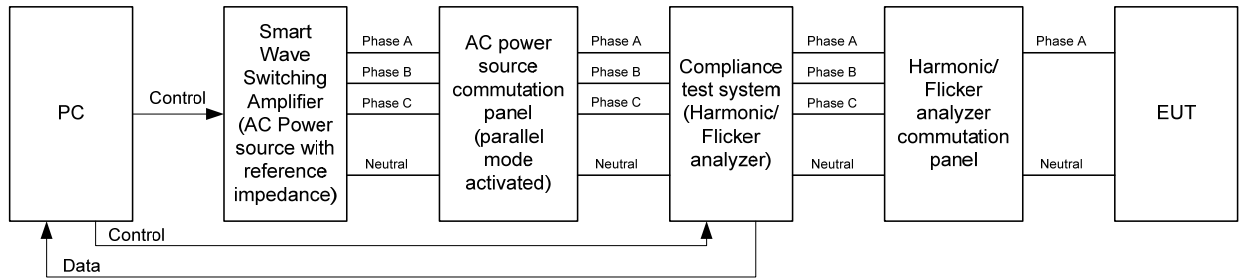

Photograph 8.5.1 Setup for voltage fluctuations and flicker test





Test specification:	Voltage fluctuations and flicker at AC mains input port		
Test procedure:	EN 301 489-1, Section 8.6, EN 61000-3-3; EN 61000-6-3, Table 2		
Test mode:	Compliance	Verdict:	PASS
Date(s):	14-Sep-20		
Temperature: 23 °C	Relative Humidity: 46 %	Air Pressure: 1010 hPa	Power: 230 VAC, 50 Hz
Remarks:			

Table 8.5.2 Voltage fluctuations and short term flicker test results

Vrms at the end of test (Volt):	230.11			
Highest dt (%):	0.00	Test limit (%):	3.30	Pass
Time(mS) > dt:	0.0	Test limit (mS):	500.0	Pass
Highest dc (%):	0.00	Test limit (%):	3.30	Pass
Highest dmax (%):	0.00	Test limit (%):	4.00	Pass
Highest Pst (10 min. period):	0.001	Test limit:	1.000	Pass

Long term flicker test was considered unnecessary as the value of short term flicker was lower than 0.65 under the most unfavourable sequence of the EUT operation.

Reference numbers of test equipment used

HL 2364	HL 2417	HL 2666					
---------	---------	---------	--	--	--	--	--

Full description is given in Appendix A.

Test specification:	Immunity to electrostatic discharge (ESD)		
Test procedure:	EN 61000-4-2; EN 55035, Section 4.2.1, Table 1; EN 61000-6-1, Table 1.3; EN IEC 61000-6-1, Table 1.4; EN 301 489-1, Section 9.3		
Test mode:	Compliance	Verdict:	PASS
Date(s):	14-Sep-20		
Temperature: 23 °C	Relative Humidity: 52 %	Air Pressure: 1010 hPa	Power: 230 VAC, 50 Hz
Remarks:			

9 Immunity tests according to EN 55035, EN IEC 61000-6-2 and EN 301 489-171 requirements

9.1 Immunity to electrostatic discharge (ESD)

9.1.1 General

This test was performed to verify the EUT immunity to electrostatic discharges from operators directly and from adjacent objects. The ESDs were applied to all parts of the EUT, which are accessible during normal operation and maintenance.

The ESD levels, performance criterion and test results are referred to in Table 9.1.1.

9.1.2 Test procedure

9.1.2.1 The EUT was set up as shown in Figure 9.1.1 and the associated photographs, energized and the EUT performance was checked.

9.1.2.2 Single contact discharges of both polarities with 1 s time interval between pulses were applied to the horizontal coupling plane (HCP) at 10 centimeter distance from the EUT. Each side of the EUT was subjected to ESDs.

9.1.2.3 Single contact discharges of both polarities with 1 s time interval between pulses were applied to the vertical coupling plane (VCP) placed 10 centimeters from the EUT. The VCP was moved, in turn, to all sides of the EUT and it was subjected to the ESDs.

9.1.2.4 Single contact discharges of both polarities with 1 s time interval between pulses were applied to conductive parts of the EUT cabinet.

9.1.2.5 Single air discharges of both polarities with 1 s time interval between pulses were applied to non-conductive parts of the EUT.

9.1.2.6 The EUT operation was monitored throughout the test for any malfunction or degradation and its performance was recorded.

9.1.2.7 Upon this the test was completed.

Figure 9.1.1 Setup for immunity to ESD, table-top EUT

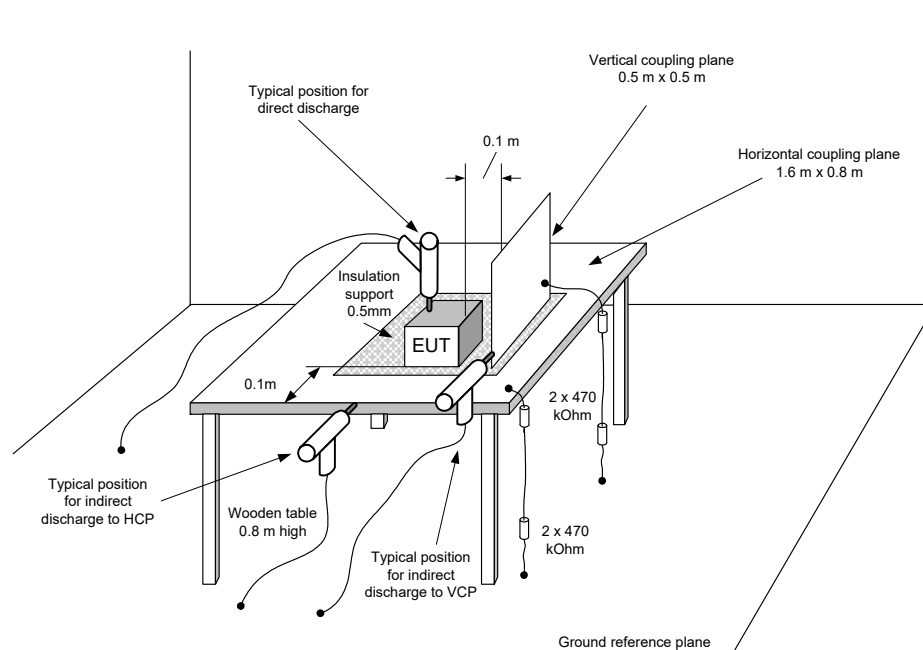

Test specification:	Immunity to electrostatic discharge (ESD)		
Test procedure:	EN 61000-4-2; EN 55035, Section 4.2.1, Table 1; EN 61000-6-1, Table 1.3; EN IEC 61000-6-1, Table 1.4; EN 301 489-1, Section 9.3		
Test mode:	Compliance	Verdict:	PASS
Date(s):	14-Sep-20		
Temperature: 23 °C	Relative Humidity: 52 %	Air Pressure: 1010 hPa	Power: 230 VAC, 50 Hz
Remarks:			

Photograph 9.1.1 Setup for immunity to ESD, general view

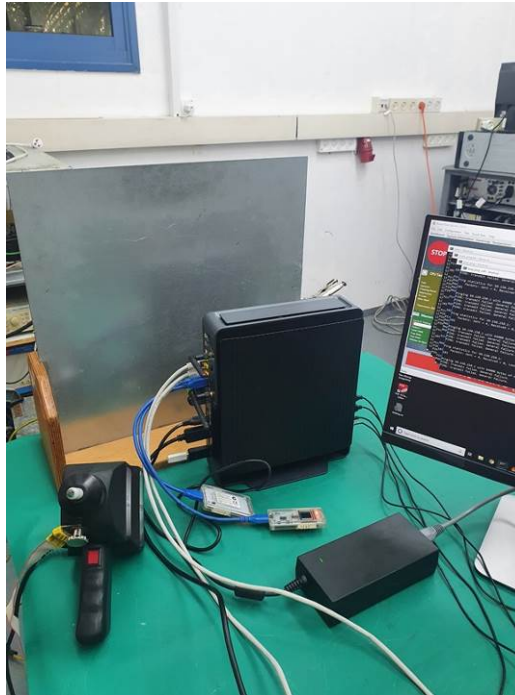

Photograph 9.1.2 Setup for immunity to ESD, EUT test points



Test specification:	Immunity to electrostatic discharge (ESD)		
Test procedure:	EN 61000-4-2; EN 55035, Section 4.2.1, Table 1; EN 61000-6-1, Table 1.3; EN IEC 61000-6-1, Table 1.4; EN 301 489-1, Section 9.3		
Test mode:	Compliance	Verdict:	PASS
Date(s):	14-Sep-20		
Temperature: 23 °C	Relative Humidity: 52 %	Air Pressure: 1010 hPa	Power: 230 VAC, 50 Hz
Remarks:			

Photograph 9.1.3 Setup for immunity to ESD, EUT test points





Test specification:	Immunity to electrostatic discharge (ESD)		
Test procedure:	EN 61000-4-2; EN 55035, Section 4.2.1, Table 1; EN 61000-6-1, Table 1.3; EN IEC 61000-6-1, Table 1.4; EN 301 489-1, Section 9.3		
Test mode:	Compliance	Verdict:	PASS
Date(s):	14-Sep-20		
Temperature: 23 °C	Relative Humidity: 52 %	Air Pressure: 1010 hPa	Power: 230 VAC, 50 Hz
Remarks:			

Table 9.1.1 Immunity to ESD test results

EUT SET UP: TABLE-TOP
 PERFORMANCE CRITERIA: B (EN 55035, EN IEC 61000-6-1)
 TT/TR (EN 301 489-1)
 NUMBER OF DISCHARGES AT EACH POINT & EACH LEVEL: 10 POSITIVE / 10 NEGATIVE

ESD applied to	Test voltage, kV	Number of test points	EUT performance description during the test	Verdict
Air discharge				
EUT	2	36*	NP	Pass
	4		NP	
	8		NP	
Contact discharge				
EUT	2	35	NP	Pass
	4		Monitor briefly blanked and self returned to normal operation.	
HCP	2	4	NP	Pass
	4		NP	
VCP	2	4	NP	Pass
	4		NP	

* 10 positive / 10 negative air discharges were applied only to the test points, where discharges occurred. At all other points dielectric was examined for sufficient insulation to prevent disruption.

Reference numbers of test equipment used

HL 4668	HL 4719	HL 4979	HL 4842	HL 5696			
---------	---------	---------	---------	---------	--	--	--

Full description is given in Appendix A.



Test specification:	Continuous RF electromagnetic field disturbances, swept and spot tests		
Test procedure:	EN 61000-4-3; EN 55035, Section 4.2.2.1/2, Table 1; EN61000-6-1, Table 1.2; EN IEC61000-6-2, Table 1.2/3; EN 301 489-1, Section 9.2		
Test mode:	Compliance	Verdict:	PASS
Date(s):	16-Sep-20		
Temperature: 23 °C	Relative Humidity: 47 %	Air Pressure: 1007 hPa	Power: 230 VAC, 50 Hz
Remarks:			

9.2 Continuous RF electromagnetic field disturbances, swept and spot tests

9.2.1 General

This test was performed to verify the EUT immunity to radiated radio frequency electromagnetic field. The radiated RF electromagnetic field levels, performance criterion and test results are referred to in Table 9.2.1.

9.2.2 Test procedure

- 9.2.2.1 The EUT was set up as shown in Figure 9.2.1 and the associated photographs, energized and the EUT performance was checked.
- 9.2.2.2 The electric field generating antenna was installed facing the EUT front panel at the specified distance.
- 9.2.2.3 The test setup was adjusted to produce the required field strength level. The field strength was monitored by the isotropic field probe, which was placed near the EUT.
- 9.2.2.4 The signal frequency was scanned throughout the frequency range.
- 9.2.2.5 The test was performed with the antennas in both vertical and horizontal polarization.
- 9.2.2.6 The test was repeated at spot frequencies.
- 9.2.2.7 The test was repeated for the rest of the EUT orientations.
- 9.2.2.8 The EUT operation was monitored throughout the test for any malfunction or degradation and its performance was recorded.
- 9.2.2.9 Upon this the test was completed.

Figure 9.2.1 Setup for radiated immunity to RF electromagnetic field test, table-top EUT

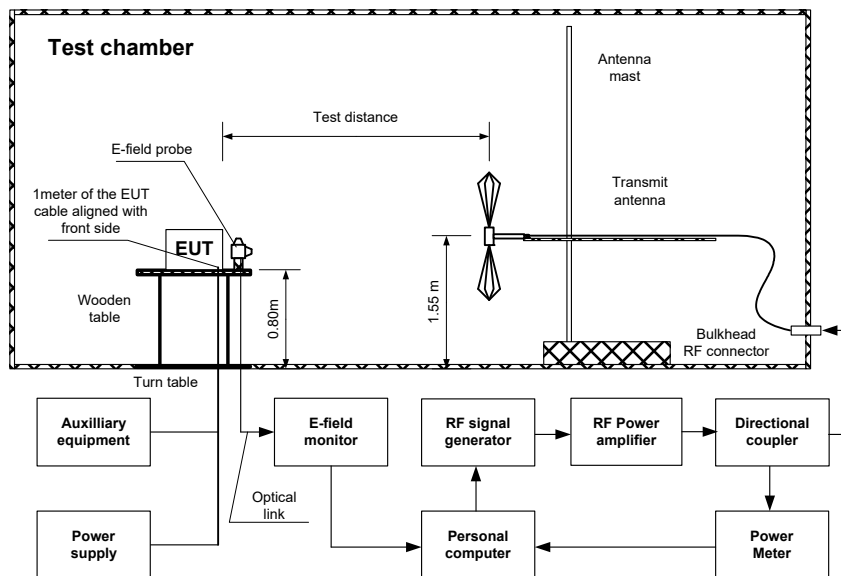



Test specification:	Continuous RF electromagnetic field disturbances, swept and spot tests		
Test procedure:	EN 61000-4-3; EN 55035, Section 4.2.2.1/2, Table 1; EN61000-6-1, Table 1.2; EN IEC61000-6-2, Table 1.2/3; EN 301 489-1, Section 9.2		
Test mode:	Compliance	Verdict:	PASS
Date(s):	16-Sep-20		
Temperature: 23 °C	Relative Humidity: 47 %	Air Pressure: 1007 hPa	Power: 230 VAC, 50 Hz
Remarks:			

Photograph 9.2.1 Setup for radiated immunity to RF electromagnetic field test, general view

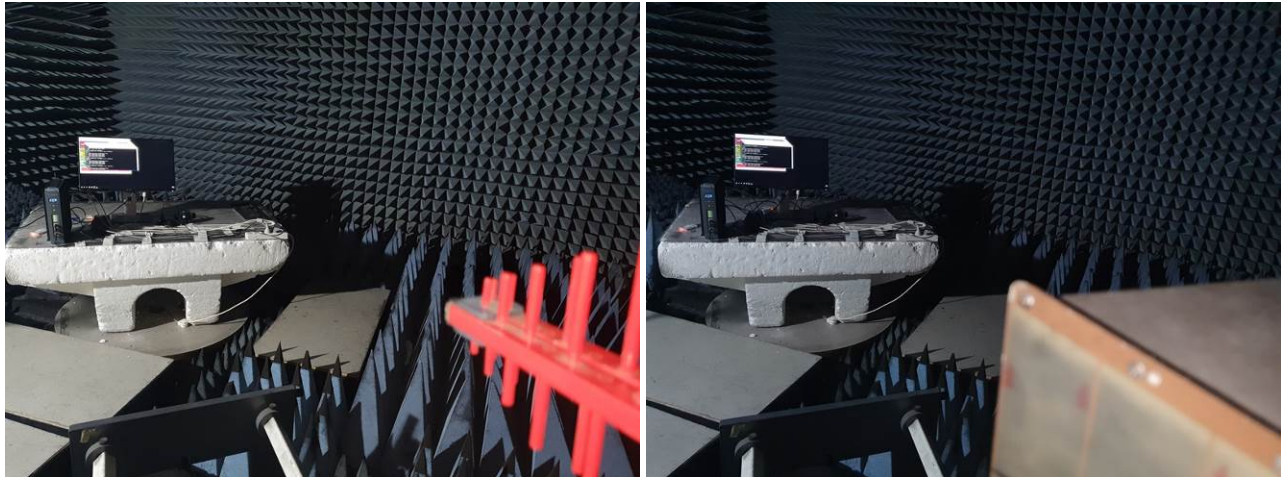

Photograph 9.2.2 Setup for radiated immunity to RF electromagnetic field test, EUT cabling





Test specification:	Continuous RF electromagnetic field disturbances, swept and spot tests		
Test procedure:	EN 61000-4-3; EN 55035, Section 4.2.2.1/2, Table 1; EN61000-6-1, Table 1.2; EN IEC61000-6-2, Table 1.2/3; EN 301 489-1, Section 9.2		
Test mode:	Compliance	Verdict:	PASS
Date(s):	16-Sep-20		
Temperature: 23 °C	Relative Humidity: 47 %	Air Pressure: 1007 hPa	Power: 230 VAC, 50 Hz
Remarks:			

Table 9.2.1 Radiated immunity to RF electromagnetic field test results

EUT SET UP: TABLE-TOP
 PERFORMANCE CRITERIA: A (EN 55035, EN IEC 61000-6-1)
 CT/CR (EN 301 489-1)
 TEST SITE: ANECHOIC CHAMBER
 ANTENNA TO EUT DISTANCE: 2.4 m
 MODULATION: 80% AM with 1 kHz
 DWELL TIME: 3 s
 FREQUENCY STEP: 1 % of current frequency
 FREQUENCY RANGE: 80 – 1000 MHz

EUT orientation*	Antenna polarization	Field strength**, V _{rms} /m	EUT performance description during the test	Verdict
0°	Vertical	3	NP	Pass
	Horizontal		NP	
90°	Vertical		NP	Pass
	Horizontal		NP	
180°	Vertical		NP	Pass
	Horizontal		NP	
270°	Vertical		NP	Pass
	Horizontal		NP	

FREQUENCY RANGE: 1000 – 6000 MHz (EN 301 489-1, EN IEC 61000-6-1)
 SPOT FREQUENCIES: 1800, 2600, 3500, 5000 MHz (±1%) (EN 55035)

EUT orientation*	Antenna polarization	Field strength**, V _{rms} /m	EUT performance description during the test	Verdict
0°	Vertical	3	NP	Pass
	Horizontal		NP	
90°	Vertical		NP	Pass
	Horizontal		NP	
180°	Vertical		NP	Pass
	Horizontal		NP	
270°	Vertical		NP	Pass
	Horizontal		NP	

* - 0° = antenna installed facing the EUT front panel.
 ** - Field strength measured prior to modulation.

Reference numbers of test equipment used

HL 0659	HL 0661	HL 2024	HL 2432	HL 2697	HL 3025	HL 5062	HL 5110
HL 3158	HL 3864	HL 4232	HL 4938	HL 5740			

Full description is given in Appendix A.



Test specification:	Conducted immunity to electrical fast transients/ bursts (EFT/ B)		
Test procedure:	EN 61000-4-4; EN 55035, Section 4.2.4, Tables 2, 3, 4; EN 61000-6-1, Tables 2.2, 3.3, 4.5, 5.2; EN IEC 61000-6-1, Tables 4.5, 3.3, 2.3; EN 301 489-1, Section 9.4		
Test mode:	Compliance	Verdict:	PASS
Date(s):	13-Sep-20		
Temperature: 25 °C	Relative Humidity: 52 %	Air Pressure: 1001 hPa	Power: 230 VAC, 50 Hz
Remarks:			

9.3 Conducted immunity to electrical fast transient/ burst (EFT/ B)

9.3.1 General

This test was performed to verify the EUT conducted immunity to the electrical fast transient/ burst (EFT/B) applied to the EUT power and telecommunication lines.

The EFT/B levels, performance criterion and test results are referred to in Table 9.3.1.

9.3.2 Test procedure for three-wire power line application

9.3.2.1 The EUT was set up as shown in Figure 9.3.1 and the associated photograph, energized and the EUT performance was checked.

9.3.2.2 The EFT/B generator output parameters (voltage, frequency repetition and duration) were adjusted as referred to in Table 9.3.1 and the bursts were applied to the EUT power line.

9.3.2.3 The EUT operation was monitored throughout the test for any malfunction or degradation and its performance was recorded.

9.3.2.4 Upon this the test was completed.

9.3.3 Test procedure for telecommunication line application

9.3.3.1 The EUT was set up as shown in Figure 9.3.2 and the associated photograph, energized and the EUT performance was checked.

9.3.3.2 The line was placed into the capacitive coupling clamp. The EFT/B generator output parameters (voltage, frequency repetition and duration) were adjusted as referred to in Table 9.3.1 and the bursts were applied to the EUT telecommunication line.

9.3.3.3 The EUT operation was monitored throughout the test for any malfunction or degradation and its performance was recorded.

9.3.3.4 Upon this the test was completed.

Test specification:	Conducted immunity to electrical fast transients/ bursts (EFT/ B)		
Test procedure:	EN 61000-4-4; EN 55035, Section 4.2.4, Tables 2, 3, 4; EN 61000-6-1, Tables 2.2, 3.3, 4.5, 5.2; EN IEC 61000-6-1, Tables 4.5, 3.3, 2.3; EN 301 489-1, Section 9.4		
Test mode:	Compliance	Verdict:	PASS
Date(s):	13-Sep-20		
Temperature: 25 °C	Relative Humidity: 52 %	Air Pressure: 1001 hPa	Power: 230 VAC, 50 Hz
Remarks:			

Figure 9.3.1 Setup for conducted immunity to EFT/B test at power supply line, table-top EUT

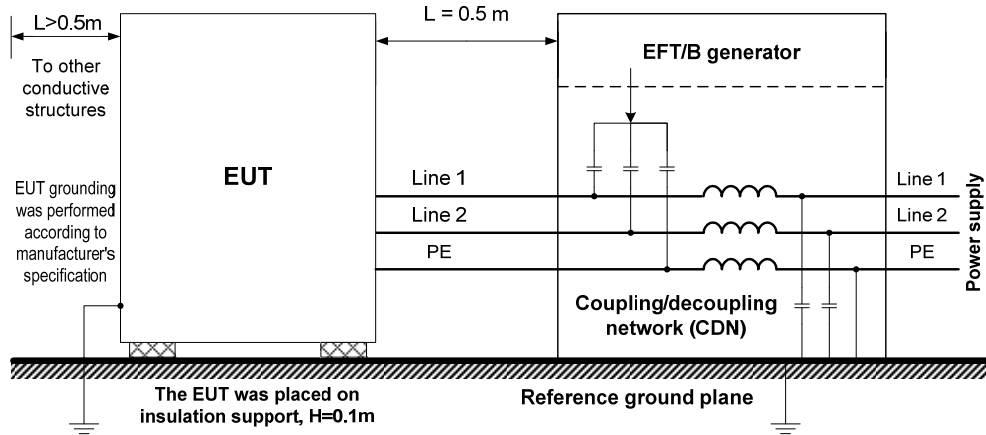

Photograph 9.3.1 Setup for conducted immunity to EFT/B at power supply line





Test specification:	Conducted immunity to electrical fast transients/ bursts (EFT/ B)		
Test procedure:	EN 61000-4-4; EN 55035, Section 4.2.4, Tables 2, 3, 4; EN 61000-6-1, Tables 2.2, 3.3, 4.5, 5.2; EN IEC 61000-6-1, Tables 4.5, 3.3, 2.3; EN 301 489-1, Section 9.4		
Test mode:	Compliance	Verdict:	PASS
Date(s):	13-Sep-20		
Temperature: 25 °C	Relative Humidity: 52 %	Air Pressure: 1001 hPa	Power: 230 VAC, 50 Hz
Remarks:			

Figure 9.3.2 Setup for conducted immunity to EFT/B test at telecommunication line, table-top EUT

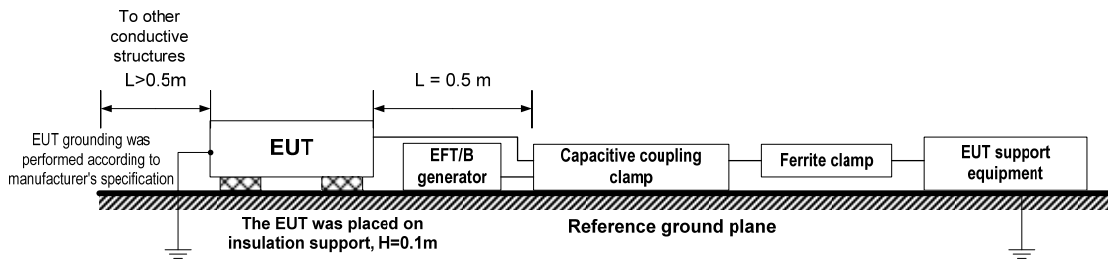

Photograph 9.3.2 Setup for conducted immunity to EFT/B at telecommunication line

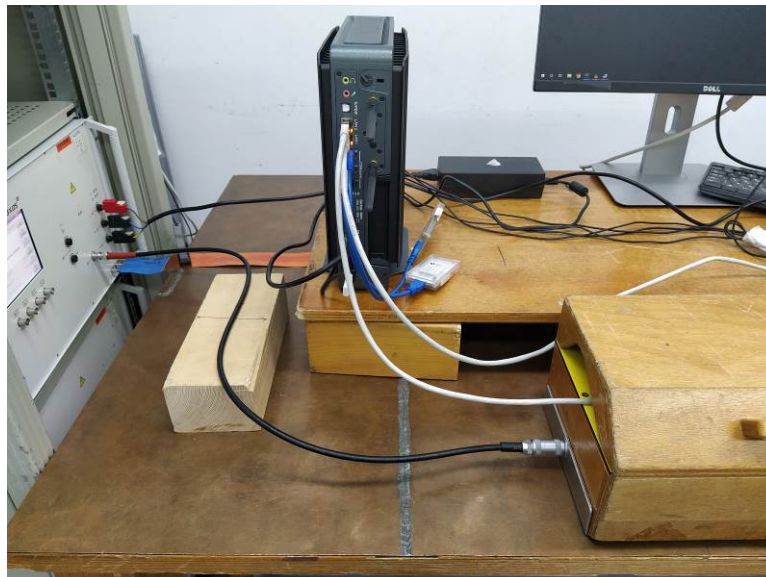



Test specification:	Conducted immunity to electrical fast transients/ bursts (EFT/ B)		
Test procedure:	EN 61000-4-4; EN 55035, Section 4.2.4, Tables 2, 3, 4; EN 61000-6-1, Tables 2.2, 3.3, 4.5, 5.2; EN IEC 61000-6-1, Tables 4.5, 3.3, 2.3; EN 301 489-1, Section 9.4		
Test mode:	Compliance	Verdict:	PASS
Date(s):	13-Sep-20		
Temperature: 25 °C	Relative Humidity: 52 %	Air Pressure: 1001 hPa	Power: 230 VAC, 50 Hz
Remarks:			

Table 9.3.1 Conducted immunity to EFT/ B test results

EUT SET UP: TABLE-TOP
PERFORMANCE CRITERIA: B (EN 55035, EN IEC 61000-6-1)
TT/TR (EN 301 489-1)
DURATION: 1 min
REPETITION FREQUENCY: 5 kHz
PULSE RISE TIME/ DURATION: 5 / 50 ns
BURST DURATION/ PERIOD: 15 / 300 ms

Type of disturbed line	Line description	Test voltage, kV	EFT/B polarity	EUT performance description during the test	Verdict
AC power of AC/DC adapter	Line 1, Line 2 & PE	1.0	Positive	NP	Pass
			Negative	NP	
Telecom	Ethernet (LAN)	0.5	Positive	NP	Pass
			Negative	NP	

Reference numbers of test equipment used

HL 5184	HL 0516						
---------	---------	--	--	--	--	--	--

Full description is given in Appendix A.



Test specification:	Conducted immunity to voltage surges		
Test procedure:	EN 61000-4-5; EN 55035, Section 4.2.5, Tables 2, 3, 4; EN 61000-6-1, Tables 3.2, 4.4; EN IEC 61000-6-1, Tables 4.4, 3.2, 2.2; EN 301 489-1, Section 9.8		
Test mode:	Compliance	Verdict:	PASS
Date(s):	13-Sep-20		
Temperature: 25 °C	Relative Humidity: 54 %	Air Pressure: 1001 hPa	Power: 230 VAC, 50 Hz
Remarks:			

9.4 Conducted immunity to voltage surges

9.4.1 General

This test was performed to verify the EUT immunity to high-energy surges produced by switching and indirect lightning transients.

The surge levels, performance criterion and test results are referred to in the associated table.

9.4.2 Test procedure for three-wire power line application

9.4.2.1 The EUT was set up as shown in Figure 9.4.1 and the associated photograph, energized and the EUT performance was checked.

9.4.2.2 The surge generator output parameters (voltage and pulse shape) were adjusted as referred to in Table 9.4.1. Voltage surges of both polarities were applied to the EUT power port in differential (line to line) and common (line to ground) modes with 1 per minute repetition rate.

9.4.2.3 The EUT operation was monitored throughout the test for any malfunction or degradation and its performance was recorded.

9.4.2.4 Upon this the test was completed.

Test specification:	Conducted immunity to voltage surges		
Test procedure:	EN 61000-4-5; EN 55035, Section 4.2.5, Tables 2, 3, 4; EN 61000-6-1, Tables 3.2, 4.4; EN IEC 61000-6-1, Tables 4.4, 3.2, 2.2; EN 301 489-1, Section 9.8		
Test mode:	Compliance	Verdict:	PASS
Date(s):	13-Sep-20		
Temperature: 25 °C	Relative Humidity: 54 %	Air Pressure: 1001 hPa	Power: 230 VAC, 50 Hz
Remarks:			

Figure 9.4.1 Setup for conducted immunity to voltage surges test, three-wire power line

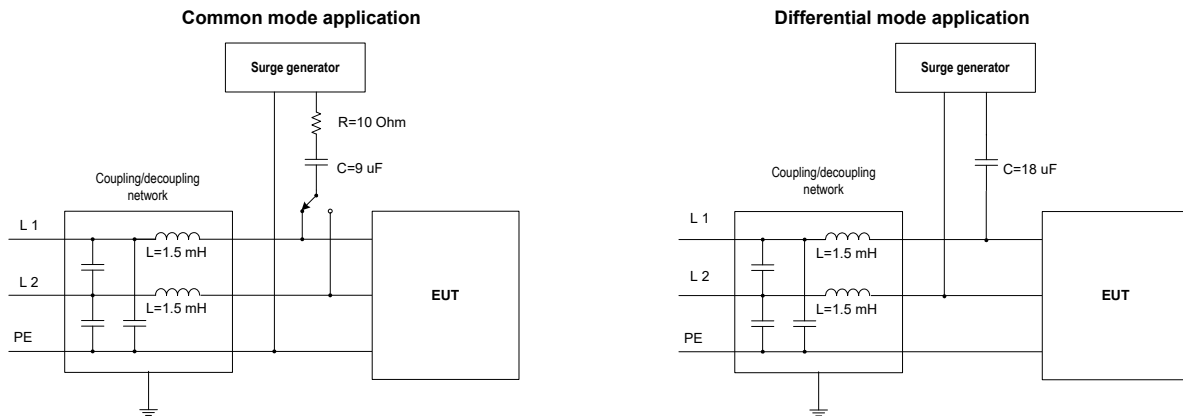

Photograph 9.4.1 Setup for conducted immunity to voltage surges at AC power line





Test specification:	Conducted immunity to voltage surges		
Test procedure:	EN 61000-4-5; EN 55035, Section 4.2.5, Tables 2, 3, 4; EN 61000-6-1, Tables 3.2, 4.4; EN IEC 61000-6-1, Tables 4.4, 3.2, 2.2; EN 301 489-1, Section 9.8		
Test mode:	Compliance	Verdict:	PASS
Date(s):	13-Sep-20		
Temperature: 25 °C	Relative Humidity: 54 %	Air Pressure: 1001 hPa	Power: 230 VAC, 50 Hz
Remarks:			

Table 9.4.1 Conducted immunity to voltage surges test results, three-wire power line

PERFORMANCE CRITERIA: B (EN 55035, EN IEC 61000-6-1)
TT/TR (EN 301 489-1)
SURGE PULSE SHAPE, Tr/Th: 1.2/50 µs
NUMBER OF PULSES: 5/5 (positive/negative) in each phase
PHAZE SYNCHRONIZATION: 0°, 90°, 180° and 270° of sine wave

Line description	Surge application	Applied voltage, kV	EUT performance description during the test	Verdict
Common mode				
AC power of AC/DC adapter	L 1 to GND	0.5	NP	Pass
		1.0	NP	
		2.0	NP	
	L 2 to GND	0.5	NP	Pass
		1.0	NP	
		2.0	NP	
Differential mode				
AC power of AC/DC adapter	L 1 to L 2	0.5	NP	Pass
		1.0	NP	

Reference numbers of test equipment used

HL 5184							
---------	--	--	--	--	--	--	--

Full description is given in Appendix A.



Test specification:	Immunity to continuous induced RF disturbances		
Test procedure:	EN 61000-4-6; EN 55035, Section 4.2.2.3, Tables 2, 3, 4; EN 61000-6-1, Tables 2.1, 3.1, 4.1, 5.1; EN IEC 61000-6-1, Tables 4.1, 3.1, 2.1; EN 301 489-1, Section 9.5		
Test mode:	Compliance	Verdict:	PASS
Date(s):	14-Sep-20		
Temperature: 24 °C	Relative Humidity: 48 %	Air Pressure: 1010 hPa	Power: 230 VAC, 50 Hz
Remarks:			

9.5 Immunity to continuous induced RF disturbances

9.5.1 General

This test was performed to verify the EUT immunity to conducted disturbances, induced by RF fields into the power and telecommunication lines in 0.15 - 80 MHz range.

The conducted disturbances levels, performance criterion and test results are referred to in Table 9.5.1.

9.5.2 Test procedure for power line application

9.5.2.1 The EUT was set up as shown in Figure 9.5.1 and the associated photograph, energized and the EUT performance was checked.

9.5.2.2 The test setup was adjusted to produce the disturbance signal as referred to in Table 9.5.1. The disturbance signal was injected into the EUT power line. The signal frequency was scanned with the step less than 1% of the fundamental frequency and the sweep rate less than 1.5×10^{-3} decade/s throughout the specified frequency range.

9.5.2.3 The EUT operation was monitored throughout the test for any malfunction or degradation and its performance was recorded.

9.5.2.4 Upon this the test was completed.

9.5.3 Test procedure for telecommunication line application, CDN injection method

9.5.3.1 The EUT was set up as shown in Figure 9.5.2 and the associated photograph, energized and the EUT performance was checked.

9.5.3.2 The test setup was adjusted to produce the disturbance signal as referred to in Table 9.5.1. The disturbance signal was injected into the EUT telecommunication line. The signal frequency was scanned with the step less than 1% of the fundamental frequency and the sweep rate less than 1.5×10^{-3} decade/s throughout the specified frequency range.

9.5.3.3 The EUT operation was monitored throughout the test for any malfunction or degradation and its performance was recorded.

9.5.3.4 Upon this the test was completed.



Test specification:	Immunity to continuous induced RF disturbances		
Test procedure:	EN 61000-4-6; EN 55035, Section 4.2.2.3, Tables 2, 3, 4; EN 61000-6-1, Tables 2.1, 3.1, 4.1, 5.1; EN IEC 61000-6-1, Tables 4.1, 3.1, 2.1; EN 301 489-1, Section 9.5		
Test mode:	Compliance	Verdict:	PASS
Date(s):	14-Sep-20		
Temperature: 24 °C	Relative Humidity: 48 %	Air Pressure: 1010 hPa	Power: 230 VAC, 50 Hz
Remarks:			

Figure 9.5.1 Setup for immunity to conducted disturbances induced by radio frequency fields at power supply line

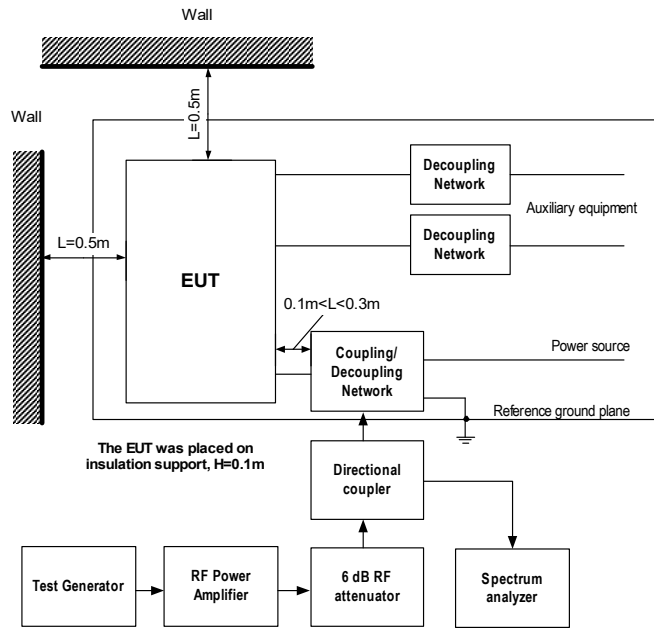

Photograph 9.5.1 Setup for immunity to conducted disturbances induced by RF fields at AC power supply line

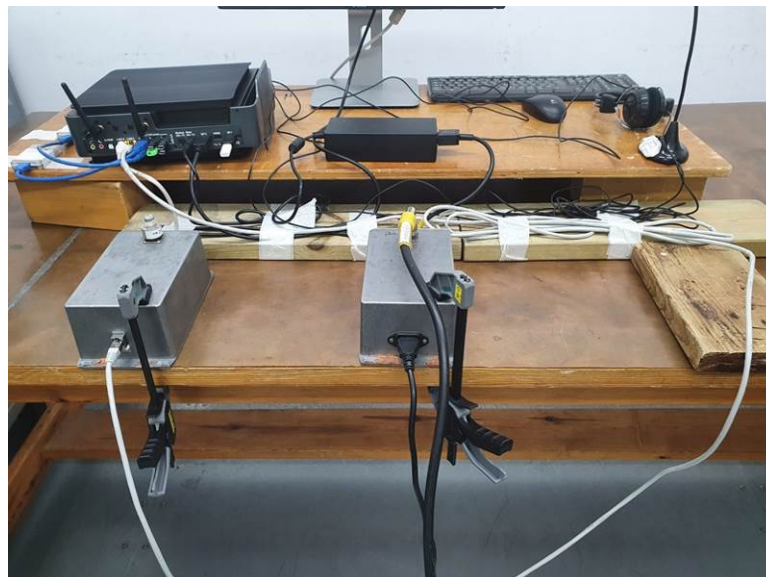



Test specification:	Immunity to continuous induced RF disturbances		
Test procedure:	EN 61000-4-6; EN 55035, Section 4.2.2.3, Tables 2, 3, 4; EN 61000-6-1, Tables 2.1, 3.1, 4.1, 5.1; EN IEC 61000-6-1, Tables 4.1, 3.1, 2.1; EN 301 489-1, Section 9.5		
Test mode:	Compliance	Verdict:	PASS
Date(s):	14-Sep-20		
Temperature: 24 °C	Relative Humidity: 48 %	Air Pressure: 1010 hPa	Power: 230 VAC, 50 Hz
Remarks:			

Figure 9.5.2 Setup for immunity to conducted disturbances induced by radio frequency fields at telecommunication line, CDN injection method

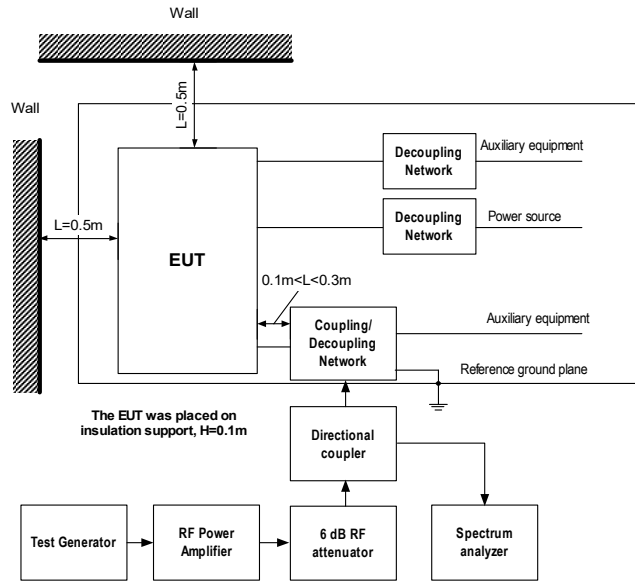

Photograph 9.5.2 Setup for immunity to conducted disturbances induced by radio frequency fields at telecommunication line, CDN injection method





Test specification:	Immunity to continuous induced RF disturbances		
Test procedure:	EN 61000-4-6; EN 55035, Section 4.2.2.3, Tables 2, 3, 4; EN 61000-6-1, Tables 2.1, 3.1, 4.1, 5.1; EN IEC 61000-6-1, Tables 4.1, 3.1, 2.1; EN 301 489-1, Section 9.5		
Test mode:	Compliance	Verdict:	PASS
Date(s):	14-Sep-20		
Temperature: 24 °C	Relative Humidity: 48 %	Air Pressure: 1010 hPa	Power: 230 VAC, 50 Hz
Remarks:			

Table 9.5.1 Immunity to conducted disturbances induced by radio frequency fields test results

EUT SET UP: TABLE-TOP
PERFORMANCE CRITERIA: A (EN 55035, EN IEC 61000-6-1)
CT/CR (EN 301 489-1)
FREQUENCY RANGE: 0.15 – 80 MHz
TYPE OF MODULATION: AM 80% @ 1 kHz
TEST VOLTAGE: 3 V_{rms} prior to modulation
DWELL TIME: 2.8 s
FREQUENCY STEP: 1 % of current frequency

Type of disturbed line	Test coupling	EUT performance during the test	Verdict
AC power power of AC/DC adapter	CDN M3	NP	Pass
Ethernet (LAN)	CDN S-T	NP	Pass

Reference numbers of test equipment used

HL 0539	HL 0675	HL 2276	HL 4261	HL 4385	HL 4481	HL 4960	HL 5038
---------	---------	---------	---------	---------	---------	---------	---------

Full description is given in Appendix A.



Test specification:	Radiated immunity to power frequency magnetic field		
Test procedure:	EN 61000-4-8 EN 55035, Section 4.2.3, Table 1.1; EN 61000-6-1, Table 1.1; EN IEC 61000-6-1, Table 1.1		
Test mode:	Compliance	Verdict:	PASS
Date(s):	13-Sep-20		
Temperature: 26 °C	Relative Humidity: 48 %	Air Pressure: 1001 hPa	Power: 230 VAC, 50 Hz
Remarks:			

9.6 Immunity to power frequency magnetic fields

9.6.1 General

This test was performed to verify the EUT immunity to magnetic fields caused by power frequency. The magnetic field levels, performance criterion and test results are referred to in Table 9.6.1.

9.6.2 Test procedure

- 9.6.2.1 The EUT was set up as shown in Figure 9.6.1 and the associated photograph, energized and the EUT performance was checked.
- 9.6.2.2 The test setup was adjusted to produce the continuous magnetic field and the EUT was exposed.
- 9.6.2.3 The procedure was repeated for the rest two orthogonal positions of the EUT.
- 9.6.2.4 The EUT operation was monitored throughout the test for any malfunction or degradation and its performance was recorded.
- 9.6.2.5 Upon this the test was completed.



Test specification:	Radiated immunity to power frequency magnetic field		
Test procedure:	EN 61000-4-8 EN 55035, Section 4.2.3, Table 1.1; EN 61000-6-1, Table 1.1; EN IEC 61000-6-1, Table 1.1		
Test mode:	Compliance	Verdict:	PASS
Date(s):	13-Sep-20		
Temperature: 26 °C	Relative Humidity: 48 %	Air Pressure: 1001 hPa	Power: 230 VAC, 50 Hz
Remarks:			

Figure 9.6.1 Setup for immunity to power frequency magnetic field test

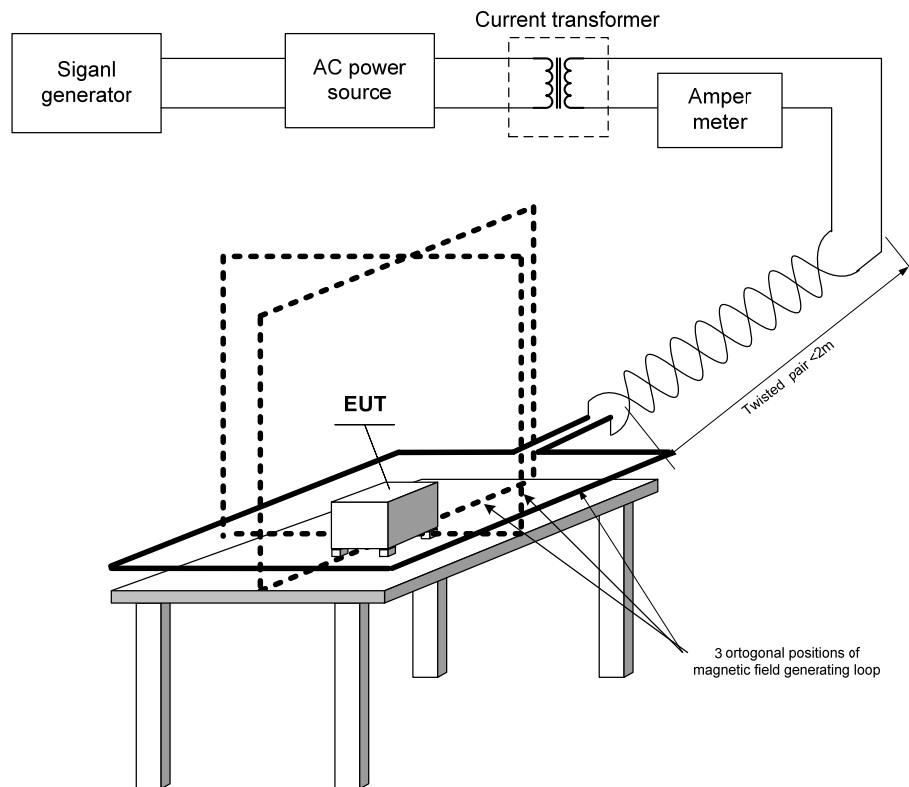

Photograph 9.6.1 Setup for immunity to power frequency magnetic field





Test specification:	Radiated immunity to power frequency magnetic field		
Test procedure:	EN 61000-4-8 EN 55035, Section 4.2.3, Table 1.1; EN 61000-6-1, Table 1.1; EN IEC 61000-6-1, Table 1.1		
Test mode:	Compliance	Verdict:	PASS
Date(s):	13-Sep-20		
Temperature: 26 °C	Relative Humidity: 48 %	Air Pressure: 1001 hPa	Power: 230 VAC, 50 Hz
Remarks:			

Table 9.6.1 Immunity to power frequency magnetic fields test results

EUT SET UP: TABLE-TOP
PERFORMANCE CRITERIA: A (EN 55035, EN IEC 61000-6-1)
DURATION: 10 min
MAGNETIC FIELD STRENGTH: 3 A/m
FREQUENCY: 50 Hz

EUT orthogonal positions	EUT performance description during the test	Verdict
X	NP	Pass
Y	NP	Pass
Z	NP	Pass

Reference numbers of test equipment used

HL 3047	HL 0133	HL 0926	HL 2489	HL 4952			
---------	---------	---------	---------	---------	--	--	--

Full description is given in Appendix A.



Test specification:	Conducted immunity to voltage dips and short interruptions		
Test procedure:	EN 61000-4-11, EN 55035, Section 4.2.6, Table 4; EN 61000-6-1, Table 4.2/3; EN IEC61000-6-1, Table 4.2/3; EN 301 489-1, Section 9.7		
Test mode:	Compliance	Verdict:	PASS
Date(s):	13-Sep-20		
Temperature: 26 °C	Relative Humidity: 48 %	Air Pressure: 1001 hPa	Power: 230 VAC, 50 Hz
Remarks:			

9.7 Immunity to voltage dips and short interruptions

9.7.1 General

This test was performed to verify the EUT immunity to voltage dips and short interruptions presented at AC power input.

The voltage dips and interruptions levels, performance criterion and test results are referred to in Table 9.7.1.

9.7.2 Test procedure

9.7.2.1 The EUT was set up as shown in Figure 9.7.1 and the associated photograph, energized and the EUT performance was checked.

9.7.2.2 The test setup was adjusted to produce voltage reduction as referred to in Table 9.7.1.

9.7.2.3 Voltage dips of each level were applied to the EUT power line.

9.7.2.4 The EUT operation was monitored throughout the test for any malfunction or degradation and its performance was recorded.

9.7.2.5 Upon this the test was completed.



Test specification:	Conducted immunity to voltage dips and short interruptions		
Test procedure:	EN 61000-4-11, EN 55035, Section 4.2.6, Table 4; EN 61000-6-1, Table 4.2/3; EN IEC61000-6-1, Table 4.2/3; EN 301 489-1, Section 9.7		
Test mode:	Compliance	Verdict:	PASS
Date(s):	13-Sep-20		
Temperature: 26 °C	Relative Humidity: 48 %	Air Pressure: 1001 hPa	Power: 230 VAC, 50 Hz
Remarks:			

Figure 9.7.1 Setup for immunity to voltage dips and short interruptions test

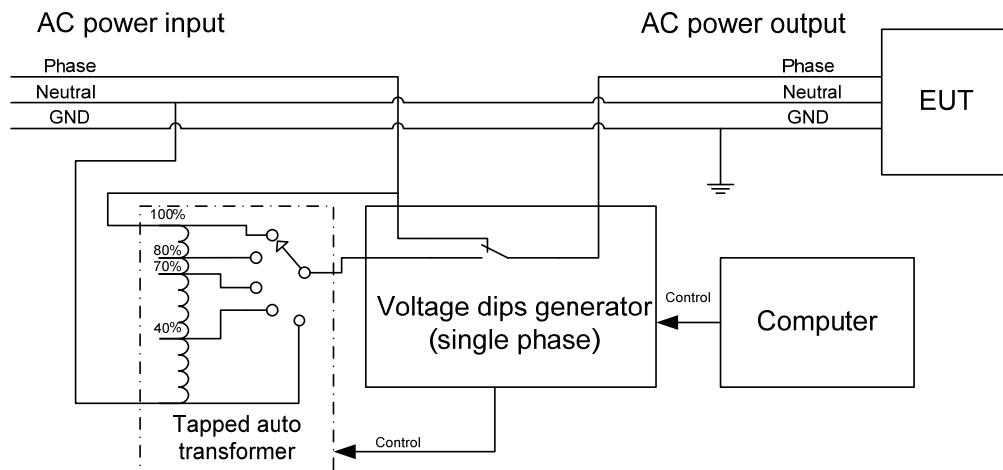

Photograph 9.7.1 Setup for immunity to voltage dips and short interruptions





Test specification:	Conducted immunity to voltage dips and short interruptions		
Test procedure:	EN 61000-4-11, EN 55035, Section 4.2.6, Table 4; EN 61000-6-1, Table 4.2/3; EN IEC61000-6-1, Table 4.2/3; EN 301 489-1, Section 9.7		
Test mode:	Compliance	Verdict:	PASS
Date(s):	13-Sep-20		
Temperature: 26 °C	Relative Humidity: 48 %	Air Pressure: 1001 hPa	Power: 230 VAC, 50 Hz
Remarks:			

Table 9.7.1 Immunity to voltage dips and short interruptions test results

EUT SET UP: TABLE-TOP
NUMBER OF DIPS: 3
REPETITION RATE: 0.1 Hz

Voltage reduction, % of V nom	Test voltage, V	Duration, ms	Performance criterion	EUT performance description during and after the test	Verdict
EN 55035, EN IEC 61000-6-1					
100% voltage dip	0	10	B	NP	Pass
100% voltage dip	0	20	B	NP	Pass
30% voltage dip	161	500	C	NP	Pass
100% voltage interruption	0	5000	C	The EUT stopped to operate during the test and returned to NP after the test with operator intervention.	Pass
EN 301 489-17/1					
100% voltage dip	0	10	TT/TR	NP	Pass
100% voltage dip	0	20	TT/TR	NP	Pass
30% voltage dip	161	500	TT/TR	NP	Pass
100% voltage interruption	0	5000	Section 9.7.3	The EUT stopped to operate during the test and returned to NP after the test with operator intervention.	Pass

Reference numbers of test equipment used

HL 5184	HL 5186					
---------	---------	--	--	--	--	--

Full description is given in Appendix A.

**10 APPENDIX A Test equipment and ancillaries used for tests**

HL No	Description	Manufacturer	Model	Ser. No.	Last Cal./Check	Due Cal./Check
0133	Generator Audio, 5 Hz - 600 kHz	Hewlett Packard	200CDR	60A77719	02-Jan-20	02-Jan-21
0516	Coupling Clamp, 100 pF	Schaffner Electronic AG	CDN 125	516	26-Oct-20	26-Oct-21
0539	Generator Signal, 10 kHz - 1.2 GHz	Marconi Instruments	2023	112121/041	12-Aug-20	12-Aug-21
0644	Probe current, 20 Hz - 100 MHz	Solar Electronics	6741-1	874916	11-Oct-20	11-Oct-21
0659	Amplifier 1 to 4 GHz, 55 W	Milmega	AS0104-55/55B	971386	02-Jul-20	02-Jul-21
0661	Generator Swept Signal, 10 MHz to 40 GHz, + 10 dBm	Hewlett Packard	83640B	3614A00266	07-Jul-20	07-Jul-21
0675	Coupler Directional, high power, 0.01 - 250 MHz, 500 W	WERLATONE	C5100	5788	11-Feb-20	11-Feb-21
0787	Transient Limiter 9 kHz-200 MHz	Hewlett Packard	11947A	3107A01877	06-Oct-20	06-Oct-21
0926	Power Source AC, 150/230 VAC	Elgar	751A	479	02-Jan-20	02-Jan-21
1909	Non inductive resistor 100 Ohm	Hermon Laboratories	NIR100	1909	16-Jan-20	16-Jan-21
2024	Amplifier, TWT, 20 W, 4 - 18 GHz	Applied Systems Engineering, Inc	20C/KU	0000878	20-Jan-20	20-Jan-21
2276	Attenuator 6 dB, 150 W, DC-1000 MHz, with 230VAC / 12VDC adapter	Hermon Laboratories	6-150	2276	22-Oct-20	22-Oct-21
2364	SmartWave Switching Amplifier	Elgar	SW5250AE-4	0317A00596	24-Aug-20	24-Aug-21
2417	Power source connection panel (for HL2364)	Hermon Laboratories	PCP-1	2417	30-Jun-20	30-Jun-21
2432	Antenna, Double-Ridged Waveguide Horn 1 to 18 GHz	EMC Test Systems	3115	00027177	19-Jan-20	19-Jan-21
2489	AC High current generator for magnetic field immunity tests	Hermon Laboratories	MFG-130A	2489	02-Jan-20	02-Jan-21
2666	Compliance Test System	California Instruments	PACS-3	72342	07-Jul-20	07-Jul-21
2697	Antenna, 30 MHz - 3.0 GHz	Sunol Sciences Corp.	JB3	A022805	10-May-20	10-May-21
3016	LISN, Two-line V-network, 9 kHz to 30 MHz, (50 uH+5 Ohm), CISPR16-1, MIL-461E	Rohde & Schwarz	ESH 3-Z5	892239/002	09-Feb-20	09-Feb-21
3025	Directional Coupler High Power, 80 to 1000 MHz, 200 W, 40 dB	WERLATONE	C 3910	6726	05-Oct-20	05-Oct-21
3047	AC Power Supply, 0 - 130 & 260v, 45 - 2000 Hz	BEHLMAN	150-C-202	5033	03-Nov-20	03-Nov-21
3158	Amplifier, 80 to 1000 MHz, 500 W	Amplifier Research	500W1000A	0323960	20-Aug-20	20-Aug-21
3864	Power Sensor 100 kHz-18.0 GHz, -50 to 30 dBm	Boonton Electronics Corp.	51015 (5E)	20890	14-Apr-20	14-Apr-21
3903	Microwave Cable Assembly, 40.0 GHz, 1.5 m, SMA/SMA	Huber-Suhner	SUCOFLEX 102A	1226/2A	06-Apr-20	06-Apr-21
4232	Precision Fixed Attenuator, 50 Ohm, 5W, 20dB, DC to 18000 MHz	Mini-Circuits	BW-N20W5+	NA	04-Jun-20	04-Jun-21
4261	Coupling-decoupling network, 150 kHz -230 MHz	Hermon Laboratories	230-M3	NA	05-May-20	05-May-21
4360	EMI Test Receiver, 20 Hz to 40 GHz.	Rohde & Schwarz	ESU40	100322	20-Jan-20	20-Jan-21
4385	Cable RF 1.8 m N type-N type/angle	AWM STYLE	MIL-C-17/RG-214U	NA	10-Sep-20	10-Sep-21
4481	Coupling-Decoupling network, 150 kHz - 230 MHz, STD 61000-4-6	Hermon Laboratories	S-T	NA	05-May-20	05-May-21
4668	ESD Generator	Schaffner-Chase EMC	NSG 435	2532	04-Aug-20	04-Aug-21
4719	Resistor for ESD tests EN 61000-4-2 470 kOhm X 2	Hermon Laboratories	R470x2	NA	10-Sep-20	10-Sep-21



HL No	Description	Manufacturer	Model	Ser. No.	Last Cal./Check	Due Cal./Check
4842	Coupling Plane Vertical, EN 61000-4-2	Hermon Laboratories	CPV-2	NA	05-Feb-20	05-Feb-21
4933	Active Horn Antenna, 1 GHz to 18 GHz	COM-POWER CORPORATION	AHA-118	701046	06-Jan-20	06-Jan-21
4938	Test Cable, 50Ω, 1.8 m, DC to 18 GHz	Mini-Circuits	CBL-6FT-SMNM+	NA	22-Apr-20	22-Apr-21
4952	Induction coil according to EN 61000-4-8, 1mx1m	Hermon Laboratories	IC-2	001	14-Jan-20	14-Jan-21
4956	Active horn antenna, 18 to 40 GHz	COM-POWER CORPORATION	AHA-840	105004	29-Jan-20	29-Jan-21
4960	Power amplifier, 150 kHz to 250 MHz, 100 W	COM-POWER CORPORATION	ACS-250-100W	711968	09-Jan-20	09-Jan-21
4979	Resistor for ESD tests EN 61000-4-2 470 kOhm X 2	Hermon Laboratories	R470x2	NA	14-May-20	14-May-21
5038	Average Power Sensor, 9 kHz - 6 GHz, -67 to 23 dBm	Rohde & Schwarz	NRP-Z91	100495	06-Nov-19	06-Dec-20
5062	Isotropic Field Probe 80 MHz - 40 GHz	Amplifier Research	FP2080	14289	01-Sep-20	01-Sep-21
5085	Attenuator, 4 dB, DC - 6 GHz, 1 W	Mini-Circuits	UNAT-4+	NA	22-May-20	22-May-21
5110	RF cable, 18 GHz, 3 m, N-type	Huber-Suhner	ST18A/Nm/Nm/3000	600818/18A	03-Aug-20	03-Aug-21
5184	EMC Compact Tester	Haefely Hipotronics	AXOS 8	184076	19-Feb-20	19-Feb-21
5186	Tapped Dips Transformer for AXOS	Haefely Hipotronics	DIP 116	184143	20-Feb-20	20-Feb-21
5288	Trilog Antenna, 25 MHz - 8 GHz, 100W	Frankonia	ALX-8000E	00809	08-Feb-19	08-Feb-22
5476	Cable, BNC/BNC, 10.5 m	Western wire	MIL-C-17G	NA	14-May-20	14-May-21
5669	Cable SF126EA/11N(x2)/3.0M, 18 GHz	Huber-Suhner	SF126EA	506775/126EA	25-Oct-20	25-Oct-21
5670	Cable SF126EA/11N(x2)/3M, 18 GHz	Huber-Suhner	SF126EA	506774/126EA	25-Oct-20	25-Oct-21
5696	Temp. & Humidity Meter, (-10 - +50) deg, (10 - 99)% RH	Mad Electronics	HTC-1	NA	02-Dec-19	02-Dec-20
5707	EMI receiver	PMM / Narda	PMM 9010F	060WW91101	22-Nov-19	22-Nov-21
5740	Coupler coaxial bi-directional 1 - 4 GHz, 20 dB	Narda	3022	71249	26-Jan-20	26-Jan-21

11 APPENDIX B Test laboratory description

Tests were performed at Hermon Laboratories Ltd., which is a fully independent, private, EMC, Radio, Safety, Environmental and Telecommunication testing facility.

Hermon Laboratories is recognized and accredited by the Federal Communications Commission (USA) for relevant parts of Code of Federal Regulations 47 (CFR 47), Test Firm Registration Number is 927748, Designation Number is IL1001; Recognized by Innovation, Science and Economic Development Canada for wireless and terminal testing (ISED), ISED #2186A, CAB identifier is IL1001; Certified by VCCI, Japan (the registration numbers are R-10808 for OATS, R-1082 for anechoic chamber, G-10869 for RE measurements above 1 GHz, C-10845 for conducted emissions site and T-11606 for conducted emissions at telecommunication ports).

The laboratory is accredited by American Association for Laboratory Accreditation (USA) according to ISO/IEC 17025 for electromagnetic compatibility, product safety, telecommunications testing, environmental simulation and calibration (for exact scope please refer to Certificate No. 839.01, 839.03 and 839.04).

Address: P.O. Box 23, Binyamina 3055001, Israel.
Telephone: +972 4628 8001
Fax: +972 4628 8277
e-mail: mail@hermonlabs.com
website: www.hermonlabs.com

Person for contact: Mr. Michael Nikishin, EMC&Radio group manager

12 APPENDIX C Abbreviations and acronyms

A	ampere
AC	alternating current
A/m	ampere per meter
AM	amplitude modulation
AVRG	average (detector)
BB	broad band
cm	centimeter
CDN	coupling/ decoupling network
CR	continuous phenomena applied to receivers
CT	continuous phenomena applied to transmitters
dB	decibel
dBm	decibel referred to one milliwatt
dB(μ V)	decibel referred to one microvolt
dB(μ V/m)	decibel referred to one microvolt per meter
dB(μ A)	decibel referred to one microampere
dB Ω	decibel referred to one Ohm
DC	direct current
EMC	electromagnetic compatibility
EMI	electromagnetic interference
EN	European Norm
EUT	equipment under test
GHz	gigahertz
GND	ground
H	height
HCP	horizontal coupling plane
HL	Hermon laboratories
Hz	hertz
k	kilo
kHz	kilohertz
kV	kilovolt
L	length
LISN	line impedance stabilization network
m	meter
MHz	megahertz
min	minute
mm	millimeter
ms	millisecond
μ s	microsecond
NA	not applicable
NB	narrow band
NP	normal performance
NT	not tested
OATS	open area test site
Ω	Ohm
QP	quasi-peak
PM	pulse modulation
PS	power supply
RE	radiated emission
RF	radio frequency
rms	root mean square
s	second
TR	transient phenomena applied to receivers
TT	transient phenomena applied to transmitters
V	volt
VA	volt-ampere
VCP	vertical coupling plane
W	width

13 APPENDIX D Test equipment correction factors

Correction factor
Line impedance stabilization network
Model ESH 3-Z5
Rhode&Schwarz
Insertion Loss Calibration result
Voltage division factor (insertion loss)

Frequency, kHz	L1, dB	N, dB	Uncertainty, dB
10	0.70	0.72	±0.12
15	0.43	0.42	±0.12
20	0.30	0.28	±0.12
25	0.23	0.21	±0.12
30	0.18	0.17	±0.08
40	0.15	0.12	±0.08
50	0.13	0.11	±0.08
60	0.12	0.10	±0.09
70	0.11	0.09	±0.09
80	0.10	0.08	±0.09
90	0.10	0.08	±0.09
100	0.10	0.08	±0.09
150	0.10	0.08	±0.09
170	0.10	0.08	±0.09
200	0.09	0.08	±0.09
250	0.09	0.08	±0.09
300	0.10	0.08	±0.09
350	0.10	0.09	±0.09
400	0.10	0.08	±0.09
500	0.11	0.08	±0.09
600	0.11	0.09	±0.09
700	0.11	0.09	±0.09
800	0.11	0.09	±0.09
900	0.12	0.10	±0.09
1000	0.12	0.10	±0.09
1200	0.13	0.10	±0.16
1500	0.13	0.12	±0.16
2000	0.15	0.13	±0.16
2500	0.17	0.14	±0.16
3000	0.18	0.15	±0.16
4000	0.21	0.19	±0.16
5000	0.25	0.21	±0.16
7000	0.38	0.32	±0.16
10000	0.49	0.40	±0.16
15000	0.82	0.72	±0.16
20000	1.03	0.87	±0.16
30000	1.34	0.98	±0.32

The correction factor in dB is to be added to meter readings of an interference analyzer or a spectrum analyzer.

Current probe factor
Solar Electronics, model 6741-1, serial number 874916

No.	Parameter	Set / Applied	Historical	Measured	Deviation	Tolerance	Uncertainty
1	Transfer Admittance	0.02 kHz	52.3 dB(S)	52.3 dB(S)	-0.1	NA	+0.97/-1.25 dB
2		0.03 kHz	48.9 dB(S)	48.7 dB(S)	-0.1	NA	+0.61/-0.72 dB
3		0.05 kHz	43.7 dB(S)	44.4 dB(S)	0.7	NA	+0.44/-0.49 dB
4		0.1 kHz	38.0 dB(S)	38.4 dB(S)	0.4	NA	+0.35/-0.38 dB
5		0.3 kHz	28.7 dB(S)	29.0 dB(S)	0.3	NA	+0.33/-0.35 dB
6		0.5 kHz	24.3 dB(S)	24.7 dB(S)	0.3	NA	+0.32/-0.35 dB
7		1 kHz	18.5 dB(S)	18.8 dB(S)	0.3	NA	+0.32/-0.35 dB
8		2 kHz	12.9 dB(S)	13.0 dB(S)	0.2	NA	+0.32/-0.35 dB
9		3 kHz	9.8 dB(S)	9.9 dB(S)	0.1	NA	+0.32/-0.35 dB
10		4 kHz	7.9 dB(S)	7.9 dB(S)	0.0	NA	+0.32/-0.35 dB
11		5 kHz	6.5 dB(S)	6.5 dB(S)	0.0	NA	+0.32/-0.35 dB
12		6 kHz	5.5 dB(S)	5.5 dB(S)	0.0	NA	+0.32/-0.35 dB
13		7 kHz	4.8 dB(S)	4.8 dB(S)	0.0	NA	+0.32/-0.35 dB
14		8 kHz	4.3 dB(S)	4.3 dB(S)	0.0	NA	+0.32/-0.35 dB
15		9 kHz	3.9 dB(S)	3.9 dB(S)	0.0	NA	+0.32/-0.35 dB
16		10 kHz	3.6 dB(S)	3.6 dB(S)	0.0	NA	+0.32/-0.35 dB
17		20 kHz	3.0 dB(S)	2.9 dB(S)	0.0	NA	+0.26/-0.28 dB
18		30 kHz	3.1 dB(S)	3.1 dB(S)	0.0	NA	+0.42/-0.46 dB
19		40 kHz	3.2 dB(S)	3.2 dB(S)	0.0	NA	+0.42/-0.47 dB
20		50 kHz	3.3 dB(S)	3.2 dB(S)	0.0	NA	+0.42/-0.47 dB
21		60 kHz	3.3 dB(S)	3.3 dB(S)	0.0	NA	+0.42/-0.47 dB
22		70 kHz	3.3 dB(S)	3.3 dB(S)	0.0	NA	+0.42/-0.47 dB
23		80 kHz	3.3 dB(S)	3.3 dB(S)	0.0	NA	+0.42/-0.47 dB
24		90 kHz	3.3 dB(S)	3.3 dB(S)	0.0	NA	+0.42/-0.47 dB
25		100 kHz	3.3 dB(S)	3.3 dB(S)	0.0	NA	+0.42/-0.47 dB
26		200 kHz	3.2 dB(S)	3.2 dB(S)	0.0	NA	+0.42/-0.47 dB
27		300 kHz	3.1 dB(S)	3.2 dB(S)	0.0	NA	+0.47/-0.52 dB
28		400 kHz	3.1 dB(S)	3.1 dB(S)	0.0	NA	+0.47/-0.52 dB
29		500 kHz	3.0 dB(S)	3.1 dB(S)	0.1	NA	+0.47/-0.52 dB
30		600 kHz	3.0 dB(S)	3.1 dB(S)	0.1	NA	+0.47/-0.52 dB
31		700 kHz	3.0 dB(S)	3.0 dB(S)	0.1	NA	+0.47/-0.52 dB
32		800 kHz	2.9 dB(S)	3.0 dB(S)	0.1	NA	+0.47/-0.52 dB
33		900 kHz	2.9 dB(S)	3.0 dB(S)	0.1	NA	+0.47/-0.52 dB
34		1000 kHz	2.9 dB(S)	3.0 dB(S)	0.1	NA	+0.47/-0.52 dB
35		2000 kHz	2.8 dB(S)	2.9 dB(S)	0.1	NA	+0.47/-0.52 dB
36		3000 kHz	2.8 dB(S)	2.8 dB(S)	0.1	NA	+0.47/-0.52 dB
37		4000 kHz	2.7 dB(S)	2.8 dB(S)	0.1	NA	+0.47/-0.52 dB
38		5000 kHz	2.7 dB(S)	2.8 dB(S)	0.1	NA	+0.47/-0.52 dB
39		6000 kHz	2.7 dB(S)	2.8 dB(S)	0.1	NA	+0.47/-0.52 dB
40		7000 kHz	2.7 dB(S)	2.8 dB(S)	0.1	NA	+0.47/-0.52 dB
41		8000 kHz	2.7 dB(S)	2.8 dB(S)	0.1	NA	+0.47/-0.52 dB
42		9000 kHz	2.7 dB(S)	2.8 dB(S)	0.1	NA	+0.47/-0.52 dB
43		10000 kHz	2.7 dB(S)	2.8 dB(S)	0.1	NA	+0.47/-0.52 dB
44		20000 kHz	2.4 dB(S)	2.8 dB(S)	0.4	NA	+0.55/-0.63 dB
45		30000 kHz	3.4 dB(S)	3.6 dB(S)	0.1	NA	+0.55/-0.63 dB
46		40000 kHz	7.0 dB(S)	7.0 dB(S)	0.0	NA	+0.55/-0.63 dB
47		50000 kHz	3.4 dB(S)	3.5 dB(S)	0.1	NA	+0.55/-0.63 dB
48		60000 kHz	4.8 dB(S)	5.1 dB(S)	0.3	NA	+0.55/-0.63 dB
49		70000 kHz	8.5 dB(S)	8.8 dB(S)	0.3	NA	+0.55/-0.63 dB
50		80000 kHz	6.9 dB(S)	6.9 dB(S)	0.0	NA	+0.55/-0.63 dB
51		90000 kHz	5.6 dB(S)	5.7 dB(S)	0.1	NA	+0.55/-0.63 dB
52		100000 kHz	7.5 dB(S)	7.9 dB(S)	0.4	NA	+0.55/-0.63 dB

**Trilog antenna factor, 25 MHz - 8 GHz, 100W
Frankonia, model ALX-8000E, serial number00809**

Frequency, MHz	Antenna factor, dB/m		
	Vert Up	Vert Down	Delta
30	-51.19	-51.28	0.09
35	-44.03	-44.12	0.09
40	-43.07	-43.12	0.05
45	-39.61	-39.79	0.18
50	-37.84	-38.14	0.3
60	-34.93	-34.9	0.03
70	-29.76	-29.66	0.1
80	-27.69	-27.82	0.13
90	-29.05	-29.07	0.02
100	-31.19	-31.19	0
120	-31.61	-31.6	0.01
140	-28.13	-28.06	0.07
160	-27.71	-27.75	0.04
180	-26.19	-26.15	0.04
200	-28.2	-28.15	0.05
250	-27.45	-27.47	0.02
300	-29.61	-29.63	0.02
400	-31.77	-31.78	0.01
500	-32.81	-32.81	0
600	-33.64	-33.61	0.03
700	-34.21	-34.21	0
800	-35.66	-35.66	0
900	-36.99	-36.91	0.08
1000	-38	-37.91	0.09

Antenna factor in dB(1/m) is to be added to receiver meter reading in dB(μ V) to convert it into field intensity in dB(μ V/m).

Horn antenna factor
COM-POWER CORPORATION, Model ANA-118, Serial number 701046

Frequency, MHz	Measured antenna factor, dB/m
1000	-16.1
1050	-16.0
1100	-15.1
1150	-16.4
1200	-16.0
1250	-15.6
1300	-15.1
1350	-14.8
1400	-15.1
1450	-15.1
1500	-15.5
1550	-15.2
1600	-14.7
1650	-14.4
1700	-14.4
1750	-14.0
1800	-13.6
1850	-12.7
1900	-11.9
1950	-11.9
2000	-11.8
2050	-11.3
2100	-11.3
2150	-11.7
2200	-12.3
2250	-12.3
2300	-12.4
2350	-12.2
2400	-11.7
2450	-11.5
2500	-11.5
2550	-11.5
2600	-11.5
2650	-11.3
2700	-11.3
2750	-11.1
2800	-11.1
2850	-11.3
2900	-11.1
2950	-11.0
3000	-11.1
3050	-10.9
3100	-10.7
3150	-10.6
3200	-11.2
3250	-10.8
3300	-10.8
3350	-10.7
3400	-10.3
3450	-10.2
3500	-10.1

Antenna factor in dB(1/m) is to be added to receiver meter reading in dB(μ V) to convert it into field intensity in dB(μ V/m).

Horn antenna factor (continued)
COM-POWER CORPORATION, Model ANA-118, Serial number 701046

Frequency, MHz	Measured antenna factor, dB/m
3550	-10.4
3600	-10.5
3650	-10.4
3700	-10.4
3750	-10.3
3800	-10.1
3850	-10.0
3900	-9.9
3950	-9.8
4000	-9.7
4050	-9.3
4100	-8.6
4150	-8.2
4200	-8.3
4250	-8.5
4300	-8.5
4350	-8.3
4400	-8.0
4450	-7.7
4500	-7.6
4550	-7.4
4600	-7.5
4650	-7.8
4700	-7.6
4750	-6.8
4800	-6.1
4850	-5.7
4900	-5.8
4950	-5.8
5000	-6.0
5050	-5.7
5100	-5.4
5150	-5.1
5200	-4.6
5250	-4.6
5300	-4.8
5350	-5.1
5400	-5.1
5450	-4.6
5500	-4.0
5550	-3.5
5600	-3.1
5650	-3.3
5700	-3.8
5750	-4.3
5800	-4.3
5850	-4.0
5900	-3.5
5950	-3.2
6000	-3.2
6050	-3.2
6100	-3.3

Antenna factor in dB(1/m) is to be added to receiver meter reading in dB(μ V) to convert it into field intensity in dB(μ V/m).

Horn antenna factor (continued)
COM-POWER CORPORATION, Model ANA-118, Serial number 701046

Frequency, MHz	Measured antenna factor, dB/m
6150	-3.3
6200	-3.1
6250	-2.9
6300	-2.8
6350	-3.0
6400	-3.2
6450	-3.4
6500	-3.7
6550	-3.6
6600	-3.4
6650	-2.9
6700	-2.6
6750	-2.5
6800	-2.6
6850	-2.8
6900	-2.7
6950	-2.3
7000	-2.0
7050	-1.9
7100	-1.8
7150	-1.8
7200	-1.7
7250	-1.7
7300	-1.6
7350	-1.5
7400	-1.5
7450	-1.3
7500	-1.4
7550	-1.3
7600	-1.0
7650	-0.7
7700	-0.3
7750	0.1
7800	0.3
7850	0.4
7900	0.2
7950	0.1
8000	0.2
8050	0.3
8100	0.8
8150	1.1
8200	1.1
8250	1.0
8300	0.8
8350	0.5
8400	0.3
8450	0.5
8500	0.8
8550	0.9
8600	0.9
8650	0.6
8750	-0.3

Antenna factor in dB(1/m) is to be added to receiver meter reading in dB(μ V) to convert it into field intensity in dB(μ V/m).

Horn antenna factor (continued)
COM-POWER CORPORATION, Model ANA-118, Serial number 701046

Frequency, MHz	Measured antenna factor, dB/m
8800	0.0
8850	0.5
8900	0.6
8950	0.4
9000	-0.3
9050	-1.0
9100	-1.2
9150	-0.6
9200	-0.1
9250	0.0
9300	-0.1
9350	-0.5
9400	-0.7
9450	-0.4
9500	0.2
9550	0.5
9600	0.5
9650	0.3
9700	0.0
9750	0.0
9800	0.6
9850	1.4
9900	1.8
9950	1.7
10000	1.4
10100	0.8
10200	1.2
10300	1.5
10400	1.1
10500	1.6
10600	3.0
10700	2.9
10800	1.3
10900	1.0
11000	1.1
11100	0.7
11200	1.1
11300	1.5
11400	1.4
11500	0.6
11600	1.0
11700	1.4
11800	0.7
11900	0.9
12000	2.1
12100	2.1
12200	0.9
12300	1.6
12400	2.1
12500	1.2
12600	1.3
12800	1.8

Antenna factor in dB(1/m) is to be added to receiver meter reading in dB(μ V) to convert it into field intensity in dB(μ V/m).

Horn antenna factor (continued)
COM-POWER CORPORATION, Model ANA-118, Serial number 701046

Frequency, MHz	Measured antenna factor, dB/m
12900	0.6
13000	0.9
13100	1.1
13200	0.7
13300	0.9
13400	1.8
13500	2.1
13600	1.2
13700	0.8
13800	1.2
13900	1.5
14000	1.7
14100	2.2
14200	2.8
14300	3.0
14400	3.0
14500	3.3
14600	4.0
14700	5.4
14800	5.4
14900	4.7
15000	3.1
15100	2.0
15200	1.5
15300	1.4
15400	1.7
15500	1.9
15600	1.2
15700	0.2
15800	0.6
15900	1.2
16000	0.6
16100	0.6
16200	1.9
16300	2.2
16400	0.9
16500	0.7
16600	1.7
16700	1.3
16800	1.0
16900	2.0
17000	2.4
17100	1.8
17200	1.8
17300	2.5
17400	2.7
17500	3.1
17600	3.7
17700	4.3
17800	4.8
17900	5.7
18000	5.1

Antenna factor in dB(1/m) is to be added to receiver meter reading in dB(μ V) to convert it into field intensity in dB(μ V/m).

Active horn antenna factor
COM-POWER CORPORATION, Model ANA-840
Serial number 105004

Frequency, MHz	Measured antenna factor, dB/m
18000	6.3
18250	3.9
18500	4.4
18750	3.1
19000	1.5
19250	0.8
19500	0.3
19750	0.4
20000	0.4
20250	-0.2
20500	0.3
20750	1.1
21000	1.1
21250	-0.3
21500	0.1
21750	-1.4
22000	-2.3
22250	-2.6
22500	-0.9
22750	-1.6
23000	-2.2
23250	-1.1
23500	-2.5
23750	-2.7
24000	-2.3
24250	-2.8
24500	-3.1
24750	-3.3
25000	-3.0
25250	-2.5
25500	-2.8
25750	-2.2
26000	-3.2
26250	-3.1
26500	-3.0
26500	-3.0
26750	-2.5
27000	-2.9
27250	-3.5
27500	-2.9
27750	-2.7
28000	-3.9
28250	-2.2
28500	-1.8
28750	-1.3
29000	-1.3
29250	-0.1

Antenna factor in dB(1/m) is to be added to receiver meter reading in dB(μ V) to convert it into field intensity in dB(μ V/m).

Active horn antenna factor (continued)
COM-POWER CORPORATION, Model ANA-840
Serial number 105004

Frequency, MHz	Measured antenna factor, dB/m
29500	-0.8
29750	0.4
30000	0.0
30250	0.5
30500	0.1
30750	0.7
31000	0.4
31250	0.6
31500	-0.6
31750	-0.7
32000	-1.0
32250	-1.5
32500	-1.8
32750	-1.5
33000	-2.3
33250	-2.0
33500	-2.6
33750	-1.9
34000	-0.8
34250	-2.4
34500	-3.4
34750	-2.7
35000	-2.3
35250	-2.0
35500	-1.7
35750	-1.9
36000	-1.4
36250	-1.1
36500	-0.4
36750	0.1
37000	1.6
37250	1.7
37500	2.4
37750	2.6
38000	4.4
38250	4.6
38500	5.5
38750	2.9
39000	2.9
39250	2.0
39500	2.3
39750	2.7
40000	2.5

Antenna factor in dB(1/m) is to be added to receiver meter reading in dB(μ V) to convert it into field intensity in dB(μ V/m).

14 APPENDIX E Measurement uncertainties

Expanded uncertainty at 95% confidence in Hermon Labs EMC measurements

Test description	Expanded uncertainty
Conducted emissions at mains port with LISN and HP 8542E or HP 8546A receiver	9 kHz to 150 kHz: ± 3.9 dB 150 kHz to 30 MHz: ± 3.8 dB
Conducted emissions at telecommunication port with HP 8542E or HP 8546A receiver	ISN: ± 3.3 dB Current probe: ± 3.5 dB
Radiated emissions at 10 m measuring distance Horizontal polarization Vertical polarization	Biconilog antenna: ± 5.0 dB Biconical antenna: ± 5.0 dB Log periodic antenna: ± 5.1 dB Double ridged horn antenna: ± 5.3 dB Biconilog antenna: ± 5.5 dB Biconical antenna: ± 5.5 dB Log periodic antenna: ± 5.6 dB Double ridged horn antenna: ± 5.8 dB
Radiated emissions at 3 m measuring distance Horizontal polarization Vertical polarization	Biconilog antenna: ± 5.3 dB Biconical antenna: ± 5.0 dB Log periodic antenna: ± 5.3 dB Double ridged horn antenna: ± 5.3 dB Biconilog antenna: ± 6.0 dB Biconical antenna: ± 5.7 dB Log periodic antenna: ± 6.0 dB Double ridged horn antenna: ± 6.0 dB
Harmonic current	$\pm 4.0\%$
Voltage fluctuations and flickers	$\pm 5.3\%$
ESD	It has been demonstrated that calibration results are within the limits specified in the EN 61000-4-2 standard reduced by uncertainty of calibration that prove compliance with standard requirements with at least a 95% confidence. Parameters that have been calibrated and tolerances are shown below: First peak current of discharge: $\pm 10\%$ (refer to standard Table 2) Current at 30 ns: $\pm 30\%$ (refer to standard Table 2) Current at 60 ns: $\pm 30\%$ (refer to standard Table 2) Rise time: 0.7 – 1 (ns)
Radiated immunity AR FP2000 E-field probe AR FP2080 E-field probe	10 kHz to 250 MHz: ± 1.9 dB; 250 MHz to 1 GHz: ± 2.1 dB 80 MHz to 26 GHz: ± 2.7 dB; 26 GHz to 40 GHz: ± 4.0 dB
Conducted RF immunity - CDN injection - Current probe injection - Direct injection	± 1.3 dB ± 3.1 dB ± 3.1 dB

Test description	Expanded uncertainty
EFT - CDN injection - Capacitive clamp injection	It has been demonstrated that calibration results are within the limits specified in the EN 61000-4-4 standard reduced by uncertainty of calibration, that prove compliance with standard requirements with at least a 95% confidence. Parameters that have been calibrated and tolerances are shown below: Peak voltage: (0.125 to 2 kV) $\pm 10\%$ at 50 Ω Peak voltage: (0.24 to 3.8 kV) $\pm 10\%$ at 1000 Ω Rise time: 5 ns $\pm 30\%$ at 50 Ω / 5 ns $\pm 30\%$ at 1000 Ω Crest time: 50 ns $\pm 30\%$ at 50 Ω / 50 ns -15 ns / +100 ns at 1000 Ω Burst duration: 15 ms $\pm 20\%$ at 5 kHz / 0.75 ms $\pm 20\%$ at 100 kHz Burst period: 300 ms $\pm 20\%$ Repetition frequency: 5 or 100 kHz $\pm 20\%$ Peak voltage at CDN output: (0.125 to 2 kV) $\pm 10\%$ at 50 Ω under 4 kV Rise time at CDN output: 5 ns $\pm 30\%$ at 50 Ω under 4 kV Crest time at CDN output: 50 ns $\pm 30\%$ at 50 Ω under 4 kV
High voltage surges	It has been demonstrated that calibration results are within the limits specified in the EN 61000-4-5 standard reduced by uncertainty of calibration, that prove compliance with standard requirements with at least a 95% confidence. Parameters that have been calibrated and tolerances are shown below: 1.2/50 μs combination wave generator: Open-circuit output voltage: (0.5 to 6 kV) $\pm 10\%$ Short-circuit output current: (0.25 to 3 kA) $\pm 10\%$ Effective output impedance: 2 Ω $\pm 10\%$ Phase shifting: 0 to 360° $\pm 10^\circ$ Undershoot: < 30% of the output voltage Coupling: Direct 18 μ F 9 μ F+10 Ω Open-circuit front time: 1.2 μ s $\pm 30\%$ 1.2 μ s $\pm 30\%$ 1.2 μ s $\pm 30\%$ Open-circuit time to half-value: 50 μ s $\pm 20\%$ 50 μ s ± 10 μ s 50 μ s +10/-25 μ s Short-circuit front time: 8 μ s $\pm 20\%$ 8 μ s $\pm 20\%$ 2.5 μ s $\pm 30\%$ Short-circuit time to half-value: 20 μ s $\pm 20\%$ 20 μ s $\pm 20\%$ 25 μ s $\pm 30\%$ 10/700 μs combination wave generator: Open-circuit output voltage: (0.5 to 6 kV) $\pm 10\%$ Short-circuit output current: (12.5 A to 150 A) $\pm 10\%$ Effective output impedance: 40 Ω $\pm 10\%$ Open-circuit front time: 10 μ s $\pm 30\%$ Open-circuit time to half-value: 700 μ s $\pm 20\%$ Short-circuit front time: 5 μ s $\pm 20\%$ Short-circuit time to half-value: 320 μ s $\pm 20\%$
Power frequency magnetic field immunity	± 2.5 dB
Voltage dips, short interruptions and variations	It has been demonstrated that calibration results are within the limits specified in the EN 61000-4-11 standard reduced by uncertainty of calibration, that prove compliance with standard requirements with at least a 95% confidence. Parameters that have been calibrated and tolerances are shown below: Open-circuit voltage: $\pm 5\%$ Voltage change under full load: Nominal voltage: $\pm 5\%$ 70% of nominal voltage: $\pm 7\%$ 40% of nominal voltage: $\pm 10\%$
Immunity to electrical transient	$\pm 6.96\%$

Hermon Laboratories is accredited by A2LA for calibration according to present requirements of ISO/IEC 17025 and NCSL Z540-1. The accreditation is granted to perform calibration of parameters that are listed in the Scope of Hermon Laboratories Accreditation.

Hermon Laboratories calibrates its reference and transfer standards by calibration laboratories accredited to ISO/IEC 17025 by a mutually recognized Accreditation Body or by a recognized national metrology institute. All reference and transfer standards used in the calibration system are traceable to national or international standards.

In-house calibration of all test and measurement equipment is performed on a regular basis according to Hermon Laboratories calibration procedures, manufacturer calibration/verification procedures or procedures defined in the relevant standards. The Hermon Laboratories test and measurement equipment is calibrated within the tolerances specified by the manufacturers and/or by the relevant standards.

15 APPENDIX F Specification references

FCC 47CFR part 15: 2019 subpart B	Radio Frequency Devices
ANSI C63.4-2014	American National Standard for Methods of Measurement of Radio-Noise Emissions from Low-Voltage Electrical and Electronic Equipment in the Range of 9 kHz to 40 GHz.
ICES-003: 2017, Issue 6	Information Technology Equipment (Including Digital Apparatus) – Limits and methods of measurement
AS/NZS CISPR 32: 2015	Electromagnetic compatibility of multimedia equipment — Emission requirements
EN 55032: 2015	Electromagnetic compatibility of multimedia equipment — Emission requirements
EN 61000-6-3: 2007 + A1(11) + AC(12)	Electromagnetic compatibility (EMC) – Part 6-3: Generic standards – Emission standard for residential, commercial and light-industrial environments
EN 55035: 2017	Electromagnetic compatibility of multimedia equipment – Immunity requirements
CISPR 35: 2016	Electromagnetic compatibility of multimedia equipment – Immunity requirements
EN 61000-3-2: 2014	Electromagnetic compatibility (EMC) - Part 3: Limits. Section 2. Limits for harmonic current emissions for equipment with input current <16 A
EN 61000-3-3: 2013	Electromagnetic compatibility (EMC) - Part 3: Limits. Section 3: Limitation of voltage fluctuations and flicker in low-voltage supply systems for equipment with rated current <16 A
EN 301 489-17 V3.2.4: 2020	ElectroMagnetic Compatibility (EMC) standard for radio equipment and services; Part 17: Specific conditions for Broadband Data Transmission Systems; Harmonised Standard for ElectroMagnetic Compatibility
EN 301 489-1 V2.2.3: 2019	ElectroMagnetic Compatibility (EMC) standard for radio equipment and services; Part 1: Common technical requirements; Harmonised Standard for ElectroMagnetic Compatibility
EN 61000-6-1: 2007	Electromagnetic compatibility (EMC) – Part 6-2: Generic standards – Immunity for commercial and light-industrial environments
EN IEC 61000-6-1: 2019	Electromagnetic compatibility (EMC) – Part 6-1: Generic standards – Immunity standard for residential, commercial and light-industrial environments
EN 61000-4-2: 2009	Electromagnetic compatibility (EMC). Part 4: testing and measurement techniques. Section 2: Electrostatic discharge immunity test
EN 61000-4-3: 2006+A1(08)+A2(10)	Electromagnetic compatibility (EMC). Part 4: testing and measurement techniques. Section 3: Radiated, radio frequency, electromagnetic field immunity test
EN 61000-4-4: 2012	Electromagnetic compatibility (EMC). Part 4: testing and measurement techniques. Section 4: Electrical fast transient/burst immunity test
EN 61000-4-5: 2014	Electromagnetic compatibility (EMC). Part 4: testing and measurement techniques. Section 5: Surge immunity test
EN 61000-4-6: 2014	Electromagnetic compatibility (EMC) Part 4: testing and measurement techniques. Section 6: Immunity to conducted disturbances, inducted by radio-frequency fields
EN 61000-4-8: 2010	Electromagnetic compatibility (EMC). Part 4: testing and measurement techniques. Section 8: Power - frequency magnetic field immunity test
EN 61000-4-11: 2004	Electromagnetic compatibility (EMC). Part 4: testing and measurement techniques. Section 11: Voltage dips, short interruptions and voltage variations immunity test
ISO 7637-2: 2004	Road vehicles – Electrical disturbance from conduction and coupling. Part 2: Electrical transient conduction along supply lines only

END OF DOCUMENT